

★

AN 08-40SCR729-2

A.P. 2583A

HANDBOOK OF
OPERATING INSTRUCTIONS
for
RADIO SETS
SCR-729-A and SCR-729-AZ

NOTE: This handbook replaces T. O. No. 08-10-167
dated 10 May 1943 and revised 8 July 1943.

RESTRICTED
(For Official Use Only)

RESTRICTED
AN 08-40SCR729-2

Published under joint authority of the United States War and Navy Departments and the Air Council of the United Kingdom.

SECURITY NOTICE

FOR U. S. PERSONNEL: This document contains information affecting the national defense of the United States within the meaning of the Espionage Act, 50 U. S. C., 31 and 32, as amended. Its transmission or the revelation of its contents in any manner to an unauthorized person is prohibited by law. (AR-380-5) (ARTS 75½ & 76, U. S. N. REGS-1920.)

The information contained in restricted documents and the essential characteristics of restricted materiel will not be communicated to the public or to the press, but may be given to any

person known to be in the service of the United States and to persons of undoubted loyalty and discretion who are cooperating in Government work.

FOR BRITISH PERSONNEL: For Official Use Only—Not to be communicated to anyone outside His Majesty's Service. Not to be published. The information given in this document is not to be communicated, either directly or indirectly, to the press or to any person not holding an official position in His Majesty's Service.

LIST OF REVISED PAGES ISSUED

NOTE: A heavy black vertical line, to the left of the text on revised pages, indicates the extent of the revision. This line is omitted where more than 50 percent of the page is revised.

THIS ISSUE CONTAINS NO REVISIONS

ADDITIONAL COPIES OF THIS PUBLICATION MAY BE OBTAINED AS FOLLOWS:

AAF ACTIVITIES.—Submit requisitions to the Commanding General, Fairfield Air Service Command, Patterson Field, Fairfield, Ohio, Attention: Publications Distribution Branch, in accordance with AAF Regulation No. 5-9. Also, for details of Technical Order distribution, see T. O. No. 00-25-3.

NAVY ACTIVITIES.—Submit requests to the Chief, Bureau of Aeronautics, Navy Department, Washington, D. C.

BRITISH ACTIVITIES.—Submit requirements on Form 294A, in duplicate, to the Air Publications and Forms Store, New College, Leadhall Lane, Harrogate, Yorkshire, England.

TABLE OF CONTENTS

<i>Section</i>	<i>Page</i>	<i>Section</i>	<i>Page</i>
I. GENERAL DESCRIPTION	1	<i>b.</i> Installation Inspection	5
1. Introduction	1	2. Adjustment	5
2. Principal Components	1	<i>a.</i> Preliminary Operation Check	5
3. Description of Principal Components	2	<i>b.</i> Field Tests	9
<i>a.</i> Radio Receiver and Transmitter BC-800-A	2	(1) General	9
<i>b.</i> Indicator BC-929-A	3	(2) Preparation of Test Equipment IE-56-A	9
<i>c.</i> Radio Control Box BC-1145-A	3	(3) Receiver Frequency Check	9
<i>d.</i> Antenna AN-148-A (Receiving)	3	(4) Transmitter Frequency Check	11
<i>e.</i> Antenna AN-147-A (Transmitting)	3	(5) Indicator Calibration Check (Nautical Miles)	11
4. Power Requirements	3	(6) Indicator Calibration Check and Adjustment for Statute Mile Scale	13
<i>a.</i> General	3	(7) Power Output Check	13
<i>b.</i> Power Requirements of Components	3	III. OPERATION	16
II. INSTALLATION AND ADJUSTMENT	3	1. Starting the Equipment	16
1. Installation	3	2. Stopping the Equipment	16
<i>a.</i> General	3	IV. EMERGENCY REPAIR	16
<i>b.</i> Radio Receiver and Transmitter BC-800-A	5	1. General	16
<i>c.</i> Indicator BC-929-A	5	2. Common Troubles and Their Corrections	16
<i>d.</i> Radio Control Box BC-1145-A	5		
<i>e.</i> Antennas AN-148-A (Receiving)	5		
<i>f.</i> Antennas AN-147-A (Transmitting)	5		
<i>g.</i> Cording and Cables	5		

LIST OF ILLUSTRATIONS

<i>Figure</i>	<i>Page</i>	<i>Figure</i>	<i>Page</i>
1. Components of Radio Set SCR-729-A	iv	16. Pulse Width (Nautical Scale)	7
2. Radio Receiver and Transmitter BC-800-A	1	17. Calibration Signal (Nautical Scale)	7
3. Indicator BC-929-A	1	18. Components of Test Equipment IE-56-A	8
4. Radio Control Box BC-1145-A	2	19. Signal Generator I-196-B—Panel View	9
5. Transformer Connections	2	20. Frequency Meter BC-906-D	10
6. Cording Diagram	4	21. Cording Diagram of Transmitter Frequency Check	11
7. Left Side of Airplane showing (1) Antenna AN-147-A and (2) Antenna AN-148-A	4	22. Range Calibrator BC-949-A	11
8. Coaxial Cable Connections to Receiving Antenna AN-148-A	4	23. Indicator BC-936-A	12
9. Coaxial Cable Diagram	5	24. Indicator BC-929-A Calibration Check— Cording Diagram	13
10. Power Cable Diagram	6	25. Power Output Check—Cording Diagram	14
11. Control Cable Diagram	6	26. Sweep Trace (Statute Scale)	15
12. Sweep Trace (Nautical Scale)	7	27. Hash (Statute Scale)	15
13. Hash (Nautical Scale)	7	28. Sweep Trace (Statute Scale) Set for Power Output Check	15
14. Sweep Trace (Nautical Scale) Set for Power Output Check	7	29. Power Output Signal (Statute Scale)	15
15. Power Output (Nautical Scale)	7	30. Pulse Width Signal (Statute Scale)	15
		31. Calibration Signal (Statute Scale)	15

SAFETY NOTICE

This equipment employs high voltages which are dangerous and may be fatal if contacted by operating personnel. Extreme caution should be exercised when working with the equipment.

Destruction of Abandoned Materiel in the Combat Zone

In case it should become necessary to prevent the capture of this equipment and when ordered to do so, DESTROY IT SO THAT NO PART OF IT CAN BE SALVAGED, RECOGNIZED, OR USED BY THE ENEMY. BURN ALL PAPERS AND BOOKS.

Means:—

1. Explosives, when provided.
2. Hammers, axes, sledges, machetes, or whatever heavy object is readily available.
3. Burning by means of incendiaries such as gasoline, oil, paper, or wood.
4. Grenades and shots from available arms.
5. Burying all debris or disposing of it in streams or other bodies of water, where possible and when time permits.

Procedure:—

1. Obliterate all identifying marks. Destroy nameplates and circuit labels.
2. Demolish all panels, castings, switch- and instrument-boards.
3. Destroy all controls, switches, relays, connections, and meters.
4. Rip out all wiring and cut interconnections of electrical equipment. Smash gas, oil, and water-cooling systems in gas-engine generators, etc.
5. Smash every electrical or mechanical part, whether rotating, moving, or fixed.
6. Break up all operating instruments such as keys, phones, microphones, etc.
7. Destroy all classes of carrying cases, straps, containers, etc.
8. Bury or scatter all debris.

DESTROY EVERYTHING!



Unsatisfactory Report

For U. S. Army Air Force Personnel:

In the event of malfunctioning, unsatisfactory design, or unsatisfactory installation of any of the component units of this equipment, or if the material contained in this book is considered inadequate or erroneous, an Unsatisfactory Report, AAF Form No. 54, or a report in similar form, shall be submitted in accordance with the provisions of Army Air Force Regulation No. 15-54, listing:

1. Station and organization.
2. Nameplate data (type number or complete nomenclature if nameplate is not attached to the equipment).
3. Date and nature of failure.
4. Airplane model and serial number.
5. Remedy used or proposed to prevent recurrence.
6. Handbook errors or inadequacies, if applicable.

For U. S. Navy Personnel:

Report of failure of any part of this equipment during its guaranteed life shall be made on Form N. Aer. 4112, "Report of Unsatisfactory or Defective Material," or a report in similar form, and forwarded in accordance with the latest instructions of the Bureau of Aeronautics. In addition to other distribution required, one copy shall be furnished to the inspector of Naval Materiel (location to be specified) and the Bureau of Ships. Such reports of failure shall include:

1. Reporting activity.
2. Nameplate data.
3. Date placed in service.
4. Part which failed.
5. Nature and cause of failure.
6. Replacement needed (yes—no).
7. Remedy used or proposed to prevent recurrence.

For British Personnel:

Form 1022 procedure should be used when reporting failure of radio equipment.

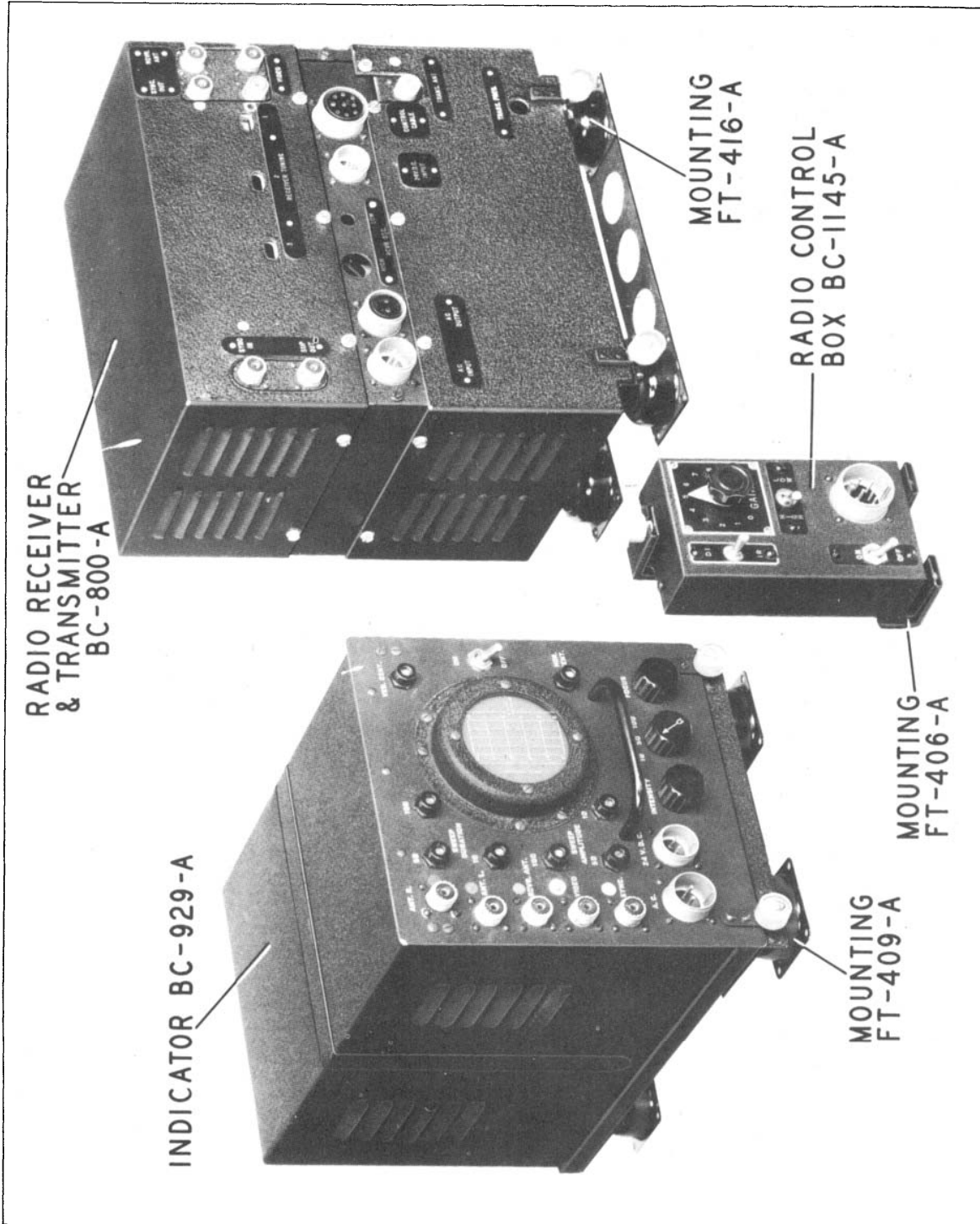

Figure 1 — Components of Radio Set SCR-729-A

SPECIAL NOTICE

References in illustrations and text of this handbook are made only to Radio Set SCR-729-A. However, all references to Radio Set SCR-729-A apply equally to Radio Set SCR-729-AZ except where an asterisk (*) calls attention to special differences.

SECTION I GENERAL DESCRIPTION

1. INTRODUCTION.

a. Radio Set SCR-729-A is a complete airborne radio receiver and transmitter with an indicator or display unit. The indicator is used to show the signal from the receiver. The receiver is designed to receive on either one of two preset frequencies; the transmitter on one preset frequency.

b. The radio set operates either independently with Indicator BC-929-A, or as an auxiliary with display units of such radio sets as Radio Sets SCR-517-B, SCR-517-C, SCR-520-A, SCR-520-B, SCR-717-A, SCR-717-B, SCR-720-A, SCR-540-A, SCR-521-A, etc.

c. Components of the radio set are normally connected for 24 volts direct current* and 400-2400 cps. alternating current. However, operation at 80 volts alternating current 400-2400 cps. has been provided for. (See paragraph 4.) Power for operation of the radio set is normally obtained from the power supply of the radio equipment with which it is associated as an auxiliary. If the associated radio equipment is not installed in the particular airplane in which Radio Set SCR-729-A is used, the 115-volt, 400-2400 cps is obtained from an inverter. The d-c power used in the operation of Radio Set SCR-729-A is obtained from the airplane battery.

2. PRINCIPAL COMPONENTS.

Principal components of Radio Set SCR-729-A or SCR-729-AZ, with their weights and overall dimensions, are listed in the table below.

Quantity Required	Unit	Dimensions			Weight (Pounds)
		Height (Inches)	Width (Inches)	Depth (Inches)	
1	Radio Receiver and Transmitter BC-800-A or BC-800-AZ	12 ¹ / ₈	12	8 ³ / ₄	34.0
1	Indicator BC-929-A or BC-929-AZ	8 ⁷ / ₈	8 ³ / ₄	16	26.0

*Radio Set SCR-729-AZ requires 12 volts direct current.

Quantity Required	Unit	Dimensions			Weight (Pounds)
		Height (Inches)	Width (Inches)	Depth (Inches)	
1	Radio Control Box BC-1145-A	3	3 ⁵ / ₈	7 ¹ / ₄	1.25
2	Antenna AN-148-A (Receiving)				4.75
2	Antenna AN-147-A (Transmitting)				
1	Mounting FT-406-A				2.5
1	Mounting FT-409-A				2.5
1	Mounting FT-416-A				0.25
As required	RF Cable RG-8/U				
1	Plug, AN3108-18-3P				0.18
1	Plug AN3108-22-17P				.25
1	Plug AN3108-22-17S				.25
2	Plug AN3108-16S-4S				.25
2	Plug AN3108-18-3S				.43
15	Plug PL-259				.75
1	Visor for Indicator				

3. DESCRIPTION OF PRINCIPAL COMPONENTS.

a. RADIO RECEIVER AND TRANSMITTER BC-800-A.

(1) This unit is a complete radio receiver and transmitter which will receive on two preset frequencies and transmit on one frequency. The front panel contains seven female sockets for coaxial connectors, two two-prong male, one two-prong female and one nine-prong female socket for power and control connections. See figure 2 for socket markings.

Section I
Paragraph 3

RESTRICTED
AN 08-40SCR729-2

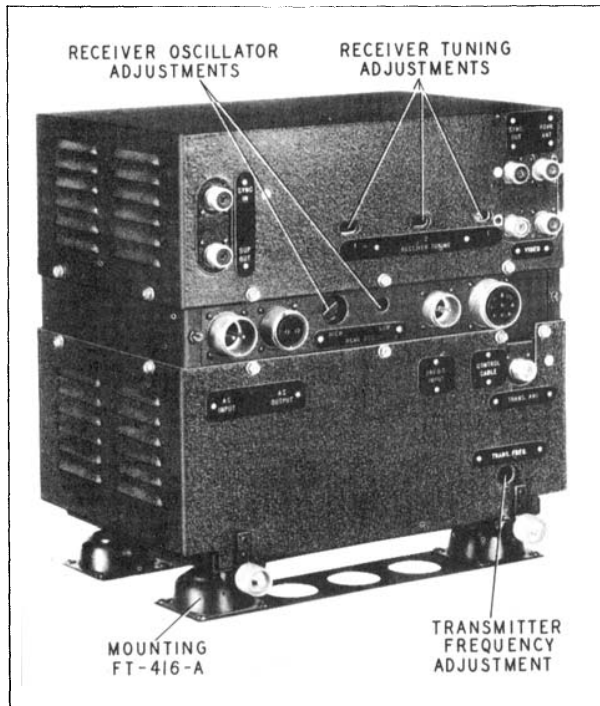

Figure 2 — Radio Receiver and Transmitter BC-800-A

(2) Three receiver tuning adjustments are located in windows of the case of the receiver under which the panel markings "RECEIVER TUNING—1-2-3" appear. The oscillator of the receiver ("RCVR OSC") is tuned by two slotted shafts marked "HIGH-LOW." The transmitter frequency adjustment is a single-screw adjustment marked "TRANS FREQ."

Note

Radio Receiver and Transmitter BC-800-A and BC-800-AZ will be modified on or about 15 May 1944 by addition of a tuning knob or a flexible tuning shaft for tuning the receiver oscillator while in flight. The new equipments will be interchangeable with the old equipments in all respects.

b. INDICATOR BC-929-A.—Indicator BC-929-A is used to show the signal received by the receiver section of Radio Receiver and Transmitter BC-800-A. The panel of the indicator has sockets for the right and left receiving antenna input, the receiving antenna output, video input, sync input and power connections. It also provides a viewing screen for one cathode-ray indicator tube. There are eight screwdriver adjustments on the front panel. One of these adjustments is for horizontal centering and one is for vertical centering of the image on the indicator screen. Three adjustments are used for adjusting sweep duration: one for each setting of the range switch and the remaining two for adjusting the amplitude of the trace for each range. The three knobs on

the lower part of the panel, marked "INTENSITY," "RANGE," and "FOCUS," are used to adjust the intensity of the image on the indicator screen to select one of three ranges covered by the equipment, and to adjust the focus. The "ON-OFF" switch turns on the d-c power for operating the motor switch in the indicator. See figure 3 for an illustration of the indicator panel.

c. RADIO CONTROL BOX BC-1145-A. — Radio Control Box BC-1145-A contains switches to turn on the components of Radio Set SCR-729-A, a receiver gain control, and a frequency selector switch. The "ON-OFF" switch controls the a-c power to the receiver-transmitter, the indicator, and also the d-c power in the receiver-transmitter. The "DI-IR" switch has three positions, namely, "DI" for constant operation, "IR" for momentary operation and a center position for standby operation. The "GAIN" control adjusts the output of the receiver. The "HIGH-LOW" switch controls the frequency of the receiver. See figure 4 for an illustration of this unit.

d. ANTENNA AN-148-A (RECEIVING).—Antenna AN-148-A is a vertical dipole with a director mounted on a single standard with a bakelite housing. There are two of these antennas used on each installation, one on each side of the fuselage with the director pointing toward the nose of the plane.

e. ANTENNA AN-147-A (TRANSMITTING). — Antenna AN-147-A consists of a dipole made of two quarter-wave rods mounted one on each side of the front of the fuselage in a horizontal position. Adapter M-358 and Plug PL-258 are used to connect the transmitter output to each of the antennas. Cord lengths are critical from Adapter M-358 to each of Antennas AN-147-A. For complete information refer to *Handbook of Maintenance Instructions for Radio Set SCR-729-A or SCR-729-AZ and Test Equipment IE-56-A.*

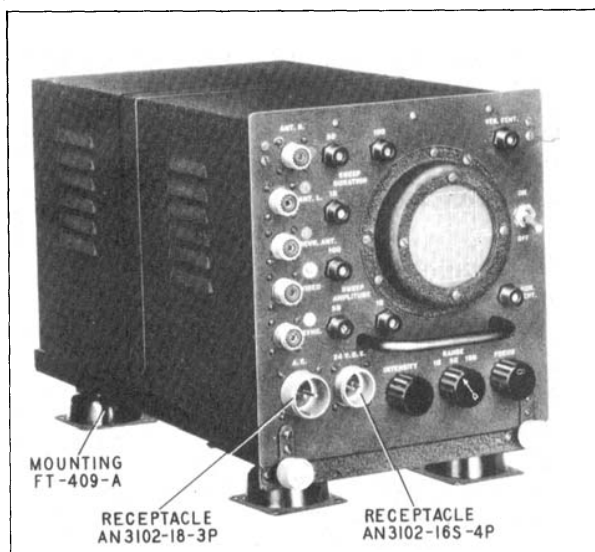

Figure 3 — Indicator BC-929-A

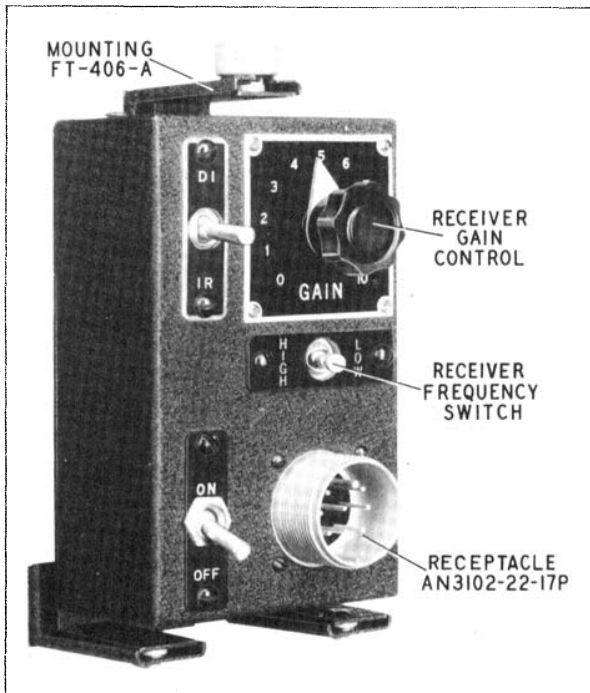

Figure 4 — Radio Control Box BC-1145-A

4. POWER REQUIREMENTS.

a. GENERAL. — Radio Set SCR-729-A requires 24 volts direct current* and 115 or 80 volts alternating current at a frequency from 400 to 2400 cps for a power source. This power is supplied from either the auxiliary equipment or from a separate inverter, depending upon the type of installation. Components normally are connected for 115-volt operation. However, taps have been provided on the power transformer of Indicator BC-929-A and the two power transformers of Radio Receiver and Transmitter BC-800-A for 80-volt a-c operation. The correct power connections should be made upon installation of the equipment in the plane. A check of the tap connections should be made if any part of Radio Set

SCR-729-A is changed. See figure 5 for the connections.

b. POWER REQUIREMENTS OF COMPONENTS.

Unit	D. C.		A. C.		
	Volts	Amperes	Volts	Watts	V.A.
Radio Receiver and Transmitter BC-800-A	24	0.5	115 volts, 400-2400 cps	135	138
Indicator BC-929-A	24	0.5	115 volts 400-2400 cps	40	42
Radio Receiver and Transmitter BC-800-AZ	12	1.0	115 volts, 400-2400 cps	135	138
Indicator BC-929-AZ	12	1.0	115 volts, 400-2400 cps	40	42

*SCR-729-AZ requires 12 volts direct current.

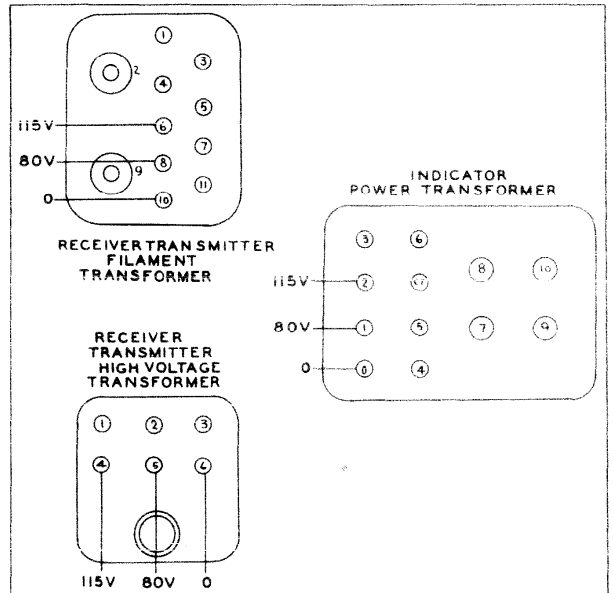

Figure 5 — Transformer Connections

**SECTION II
INSTALLATION AND ADJUSTMENT**

CAUTION

"TRANS. ANT." socket on Radio Receiver and Transmitter BC-800-A must be connected to a proper load to avoid immediate failure of transmitting tube 2C26 when the power switch on Control Box BC-1145-A is turned on. If the transmitting antenna is not connected, a 50-

ohm resistor must be substituted as a dummy load. Connect this resistor from the center conductor of the "TRANS. ANT." socket to the chassis. This resistor is shown in schematic figure 24.

1. INSTALLATION.

a. GENERAL.—Installation of Radio Set SCR-729-A

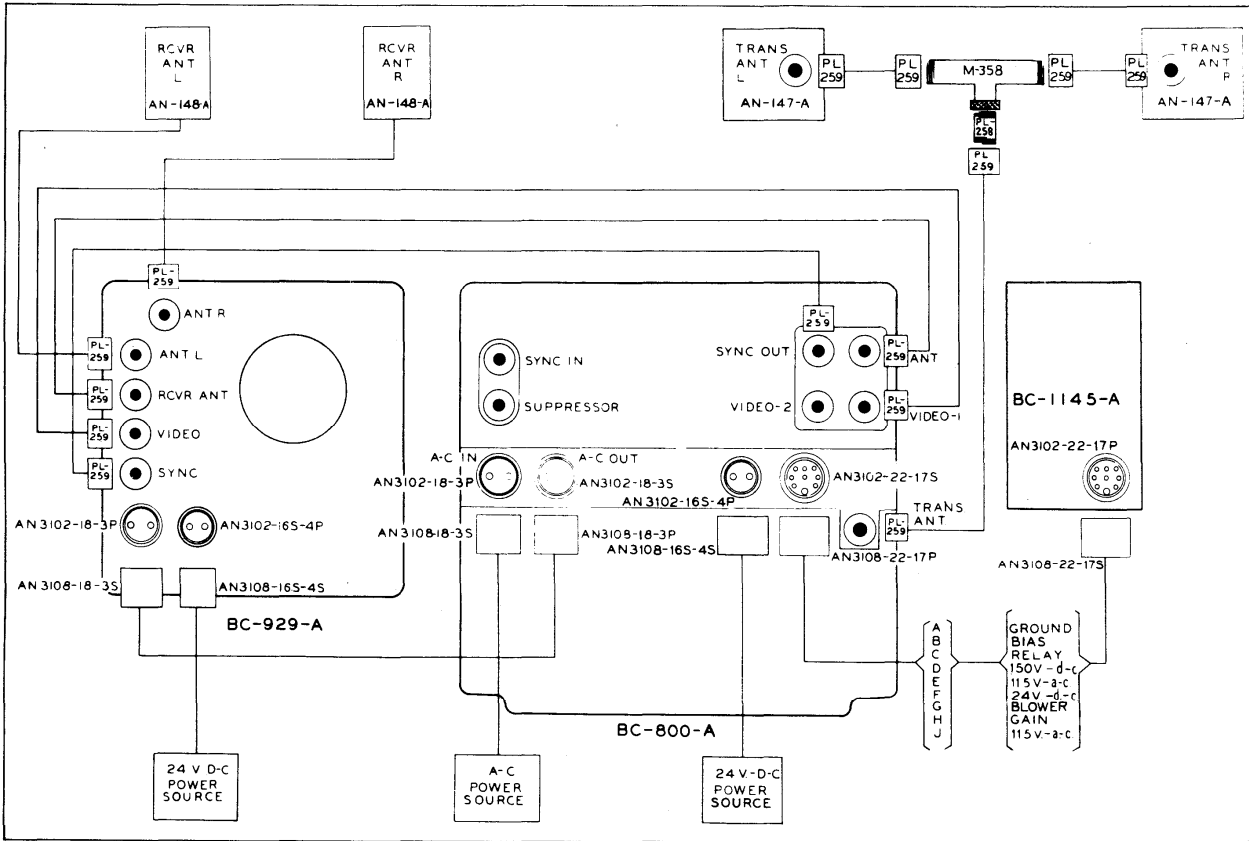

Figure 6 — Cording Diagram

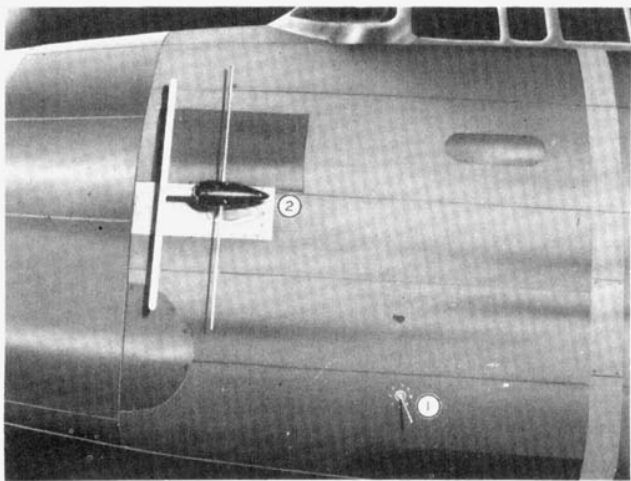

Figure 7 — Left Side of Airplane showing
(1) Antenna AN-147-A and
(2) Antenna AN-148-A

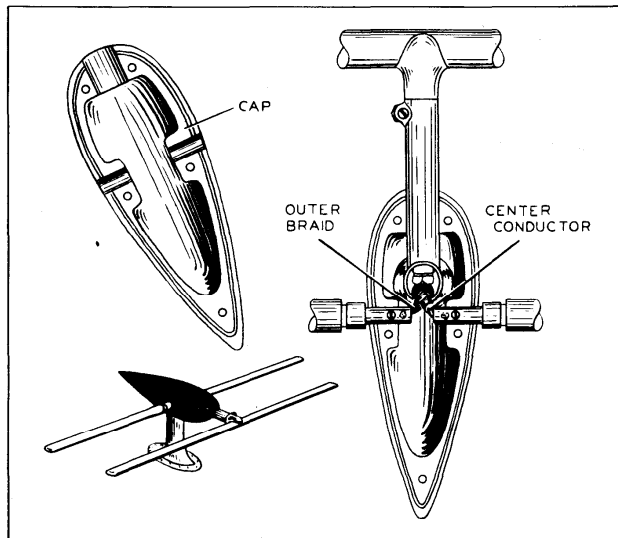

Figure 8 — Coaxial Cable Connections to
Receiving Antenna AN-148-A

is made according to the cording diagram, figure 6. Details of the antenna installation are given in figure 7 and the method of connecting the coaxial transmission lines to the receiving antennas is shown in figure 8. Details for making up the coaxial cables, power cable and control cable are given in figures 9, 10, and 11.

b. RADIO RECEIVER AND TRANSMITTER BC-800-A.—Mount receiver and transmitter so that the side containing the sockets and frequency adjustments is easily accessible while viewing the indicator screen.

c. INDICATOR BC-929-A.—Mount the indicator so that the cathode-ray tube may be viewed while operating the radio equipment with which Radio Set SCR-729-A is associated.

d. RADIO CONTROL BOX BC-1145-A.—Place the radio control box so that it is easily accessible at all times without the operator having to move from his regular operating position.

e. ANTENNAS AN-148-A (RECEIVING).—Mount the two receiving antennas on opposite sides of the fuselage near the nose of the airplane so that maximum use of their directional characteristics is achieved. (See fig. 7.) Coaxial cable connections are shown in figure 8.

f. ANTENNAS AN-147-A (TRANSMITTING).—Place the two transmitting antennas on opposite sides of the fuselage toward the front of the airplane. (See fig. 7.) Adaptor M-358 and Plug PL-258 are used to apply the output signal of the transmitter to both antennas. (See fig. 6.)

g. CORDING AND CABLES.—All cordage for connecting the components of the radio set should be cut and connected carefully. (See figs. 6, 9, 10, and 11.) Cords used for antennas are made up of Cable RG-8/U. Cables for carrying the video and synchronizing voltages between the various components and to the associated equipment shall be made of Cable RG-8/U. The shield of all these coaxial cables is grounded through the coaxial connector. (See fig. 9.) Cords carrying the power for the radio set are made from standard aircraft power and lighting cable. (See figs. 10 and 11.) The length of the various cables differs with each type of airplane installation.

When cordage is made up for connecting the components of the radio set, each cable must have sufficient length to allow for maximum movement of the components on their shock mounts, thus preventing damage to the connector. Leave sufficient slack when clamping cords to the structure of the airplane. If cords are clamped tightly, friction may cause troublesome breaks and wear in insulation.

CAUTION

Do not operate the equipment unless the transmitting antenna is connected properly or a dummy resistance load of 50 ohms is connected between the center conductor of the coaxial socket marked "TRANS. ANT." and ground. Otherwise the transmitting tube will be damaged.

ed. (Plug PL-259 with a 50-ohm resistor connected between the inner conductor and the outside of the plug is a satisfactory dummy load.)

b. INSTALLATION INSPECTION.

(1) Check all antennas for secure mounting and electrical connections. Check receiving antenna input for proper balance.

(2) Check each cord for mechanical wear and possible breaks.

(3) Check each cord for electrical connections and shorts.

(4) Check the plugs and sockets for mechanical defects and loose fittings.

(5) Check the plugs and sockets for good electrical contacts. Clean with carbon tetrachloride if necessary.

2. ADJUSTMENT.

a. PRELIMINARY OPERATION CHECK.

(1) Check the mountings of the various components.

(2) Check the transformer connections.

(3) Check the fuses.

(4) Check the cords, using the cording diagram, figure 6.

(5) Turn the "GAIN" control on Radio Control Box BC-1145-A and the "INTENSITY" control on Indicator BC-929-A to the maximum clockwise position.

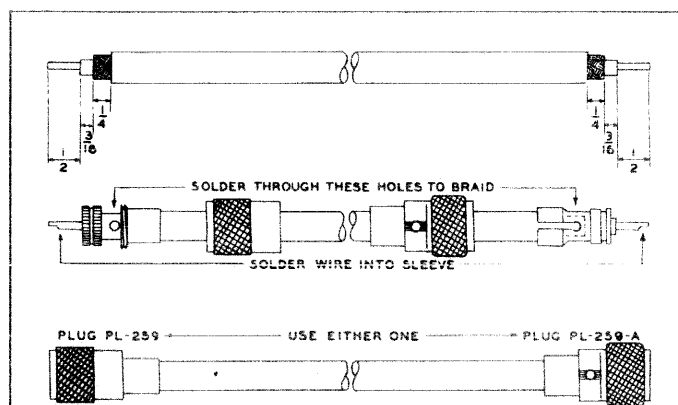

Figure 9 — Coaxial Cable Diagram

a. Remove 11/16 inch of the rubber insulation and braid shield from each end of the cable.

b. Remove 1/4 inch more of the rubber insulation from each end of the cable.

c. Remove 1/2 inch of the inner insulation from each end of the cable.

d. Place Connector PL-259 (or PL-259-A) on each end of the cable.

e. Refer to the above illustrations for soldering the braid shield and the inner conductor to the connector.

f. Slip the threaded clamp of the connector into position.

CAUTION

Do not overheat the insulation of the cable during soldering operation.

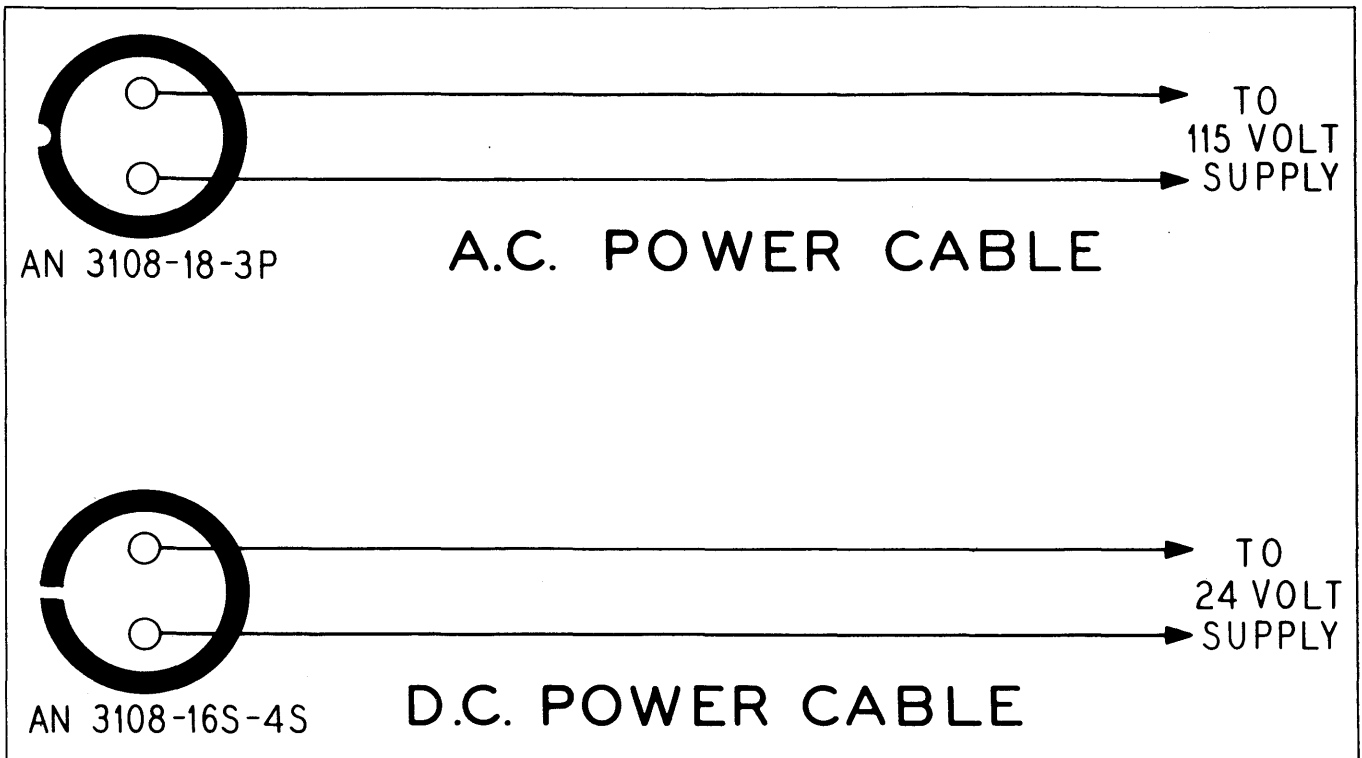

Figure 10 — Power Cable Diagram

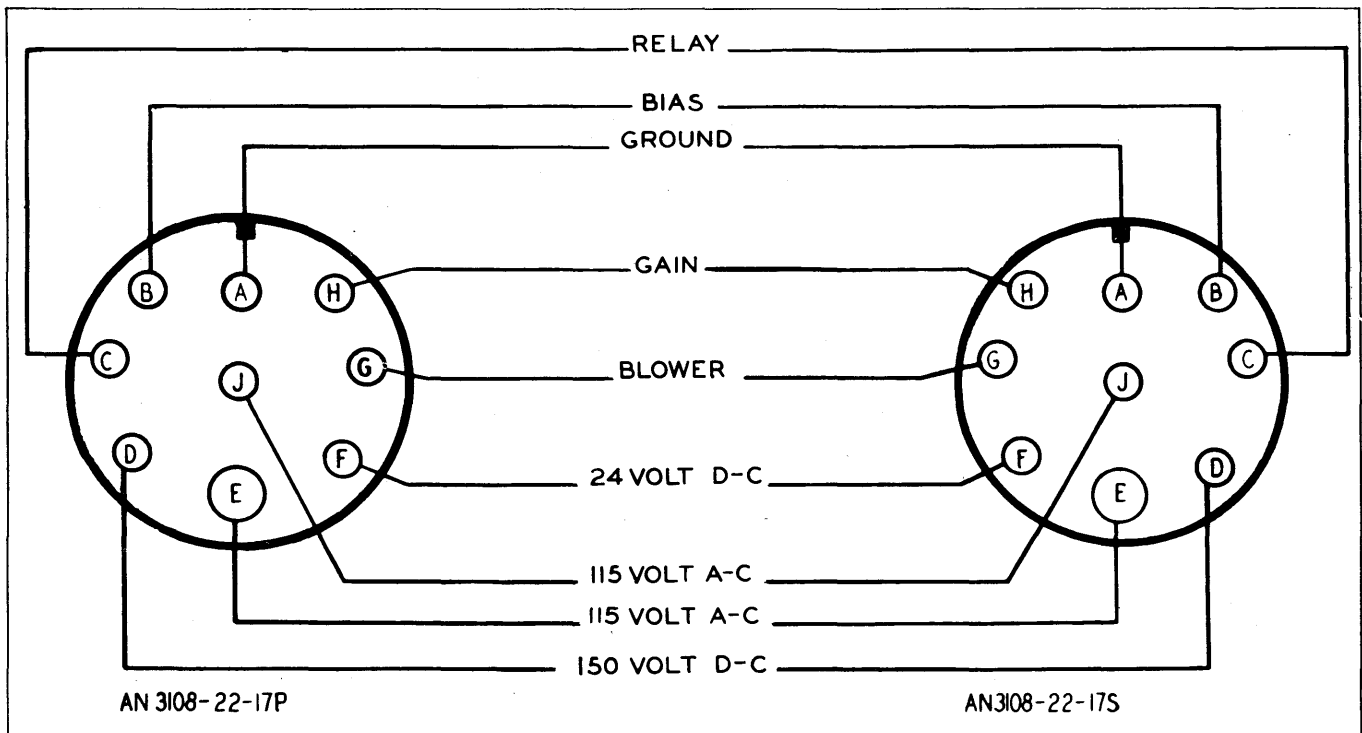

Figure 11 — Control Cable Diagram

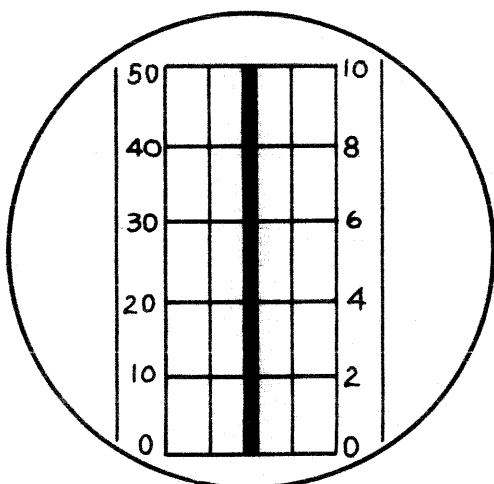

Figure 12 — Sweep Trace (Nautical Scale)

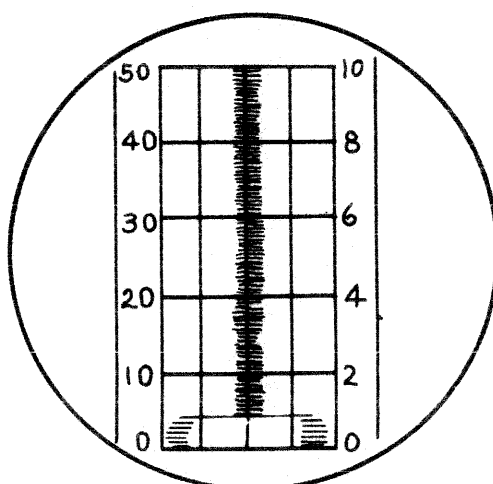

Figure 13 — Hash (Nautical Scale)

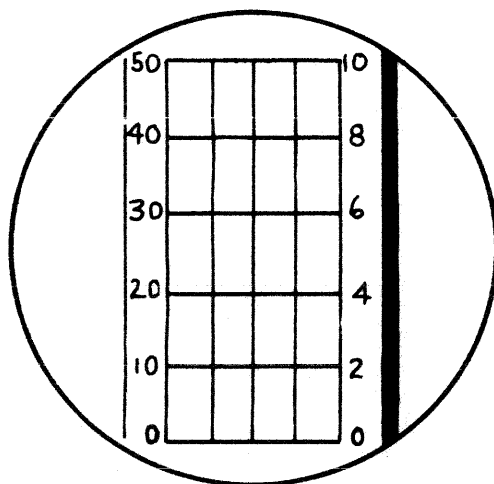

Figure 14 — Sweep Trace (Nautical Scale) Set for Power Output Check

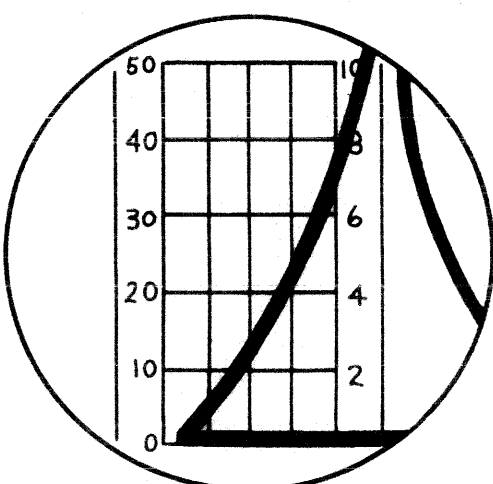

Figure 15 — Power Output (Nautical Scale)

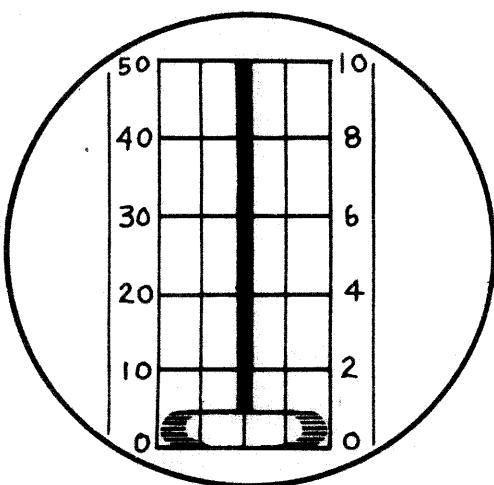

Figure 16 — Pulse Width (Nautical Scale)

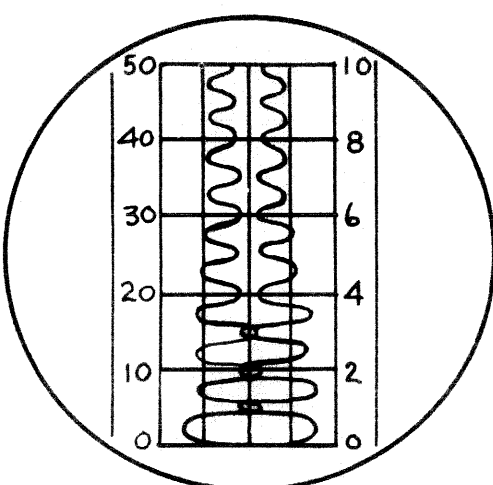

Figure 17 — Calibration Signal (Nautical Scale)

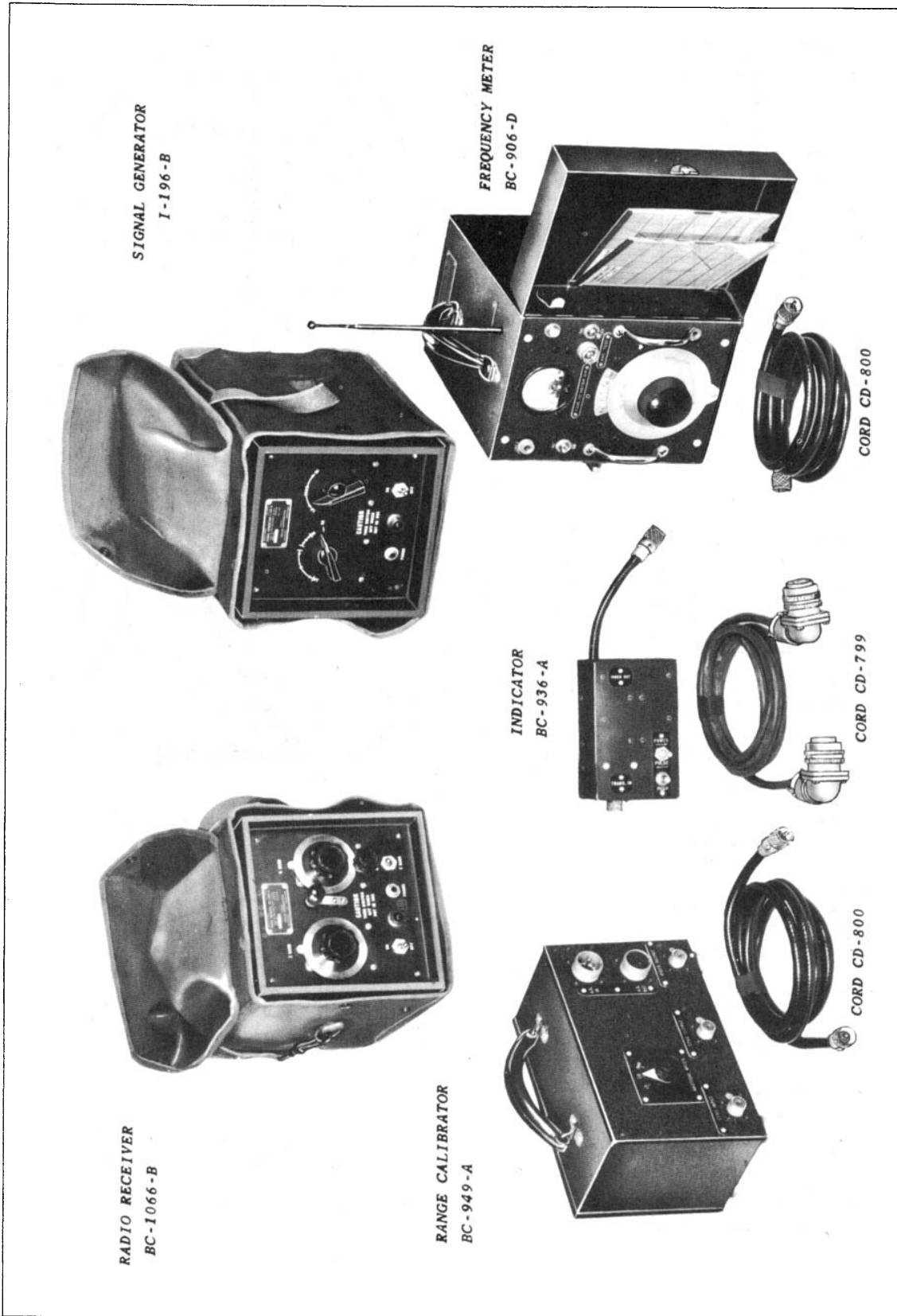

Figure 18 — Components of Test Equipment IE-56-A

CAUTION

Make sure that the transmitting antennas are connected or that a 50-ohm dummy load is connected to the "TRANS. ANT." socket on BC-800-A before turning on the equipment. Immediate failure of the transmitting tube will result otherwise.

(6) With the "DI-IR" switch in the center position, throw the "ON-OFF" switch on Radio Control Box BC-1145-A and on Indicator BC-929-A to the "ON" position. A spot should appear on the indicator tube but there will be no sweep trace, except in early sets.

(7) Make sure that the blower is in operation.

(8) Allow the set to warm up for 3 minutes and then turn the "DI-IR" switch on Radio Control Box BC-1145-A to the "DI" (constant operation) position.

(9) Adjust the "FOCUS" and "INTENSITY" control on Indicator BC-929-A for a sharp and clear trace line as indicated in figure 13.

(10) With the "GAIN" control on the control box in the maximum clockwise position, the receiver is operating if a band of hash appears on the trace line of the indicator tube. (See fig. 13.) The transmitter is operating if a pulse appears at the bottom of the sweep. (See fig. 13.)

Note

Radio Set SCR-729-A is used at times with other similar radio equipment. When other equipment is used, check the operation of this associated equipment for proper operation.

b. FIELD TESTS.

(1) GENERAL.

(a) Complete and detailed information as to fre-

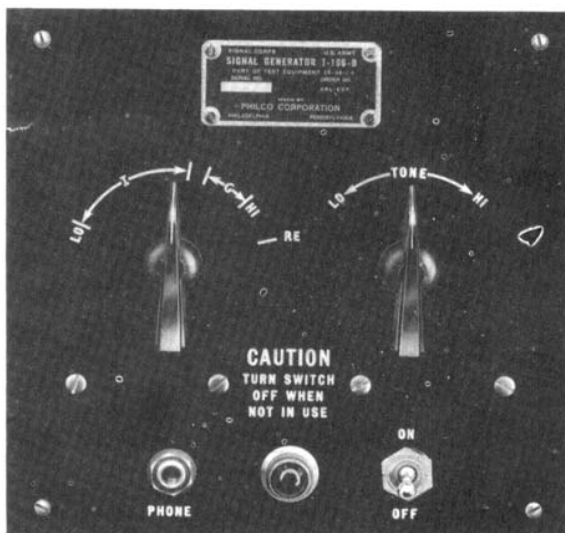

Figure 19 — Signal Generator I-196-B—Panel View

quencies and adjustments are included in the "Handbook of Maintenance Instructions for Radio Sets SCR-729-A and SCR-729-AZ and Test Equipment IE-56-A" or it may be obtained from the Communications-Officer-in-Charge.

(b) Use Test Equipment IE-56-A to check Radio Set SCR-729-A for operation and frequency coverage. Test Equipment IE-56-A consists of Signal Generator I-196-B, Test Radio Receiver BC-1066-B (not used), Frequency Meter BC-906-D, Range Calibrator BC-949-A, Power Indicator BC-936-A, two Cords CD-800 and one Cord CD-799. (See fig. 18.)

(c) Use Frequency Meter BC-906-D to calibrate Signal Generator I-196-B and to adjust the transmitter frequency of Radio Receiver and Transmitter BC-800-A. Use Signal Generator I-196-B to check the frequency of the receiver of Radio Receiver and Transmitter BC-800-A. Use Range Calibrator BC-949-A to calibrate the screen of Indicator BC-929-A. Use Indicator BC-936-A to check the power output and signal duration width of the transmitter signal of Radio Receiver and Transmitter BC-800-A. Radio Receiver BC-1066-B need not be used.

(2) PREPARATION OF TEST EQUIPMENT IE-56-A.

(a) To calibrate Signal Generator I-96-B, place the signal generator next to Frequency Meter BC-906-D.

(b) Insert the collapsible antenna into the receptacle marked "ANTENNA" on top of Frequency Meter BC-906-D. Be sure the antenna is extended its full length.

(c) Set the "HI-LO" switch on the frequency meter to "LO" and throw the "ON-OFF" switch to the "ON" position.

(d) Set the dial of the frequency meter to the high frequency calibration point, given by the Communications-Officer-in-Charge, for the setting of the receiver of Radio Receiver and Transmitter BC-800-A.

(e) Insert the plug of the headset into the "PHONE" jack of Signal Generator I-196-B.

(f) Turn on the signal generator, listening for its tone in the headset.

(g) Adjust the knob of Signal Generator I-196-B marked "LO-I-G-HI" until maximum dip is observed on the meter of Frequency Meter BC-906-D. Note this point on the signal generator dial, which is the receiver high frequency calibration point.

(h) Repeat steps (a)-(g) at the receiver low frequency calibration point.

(i) Repeat steps (a)-(g) at the mid-point frequency of the receiver high-low frequency calibration points.

(3) RECEIVER FREQUENCY CHECK.

Note

The 400-2400 cps input voltage to the equipment should be kept between 110 and 120 volts for the following adjustments.

Section II

Paragraph 2

RESTRICTED

AN 08-40SCR729-2

(a) Use Signal Generator I-196-B to send the signals used in calibrating the receiver of Radio Receiver and Transmitter BC-800-A. When the receiver is tuned to the frequency of the signal generator, maximum signal display will be observed on the indicator screen.

(b) Turn on and adjust Signal Generator I-196-B to the mid-point of the high-low frequency calibration points as determined in paragraph 2b(4)(i) this section, and place it about 25 feet in front of the airplane in which Radio Set SCR-729-A is installed.

(c) With the "DI-IR" switch in mid-position, turn the power "ON OFF" switches of Radio Set SCR-729-A, located on Radio Control Box BC-1145-A and on Indicator BC-929-A, to the "ON" position. After a 3-minute warm-up, turn the "DI-IR" switch on Control Box BC-1145-A to the "DI" position. Turn the "RANGE" switch of Indicator BC-929-A to "100." Allow the radio set to warm up for several minutes.

(d) Turn the receiver "HIGH-LOW" switch on Radio Control Box BC-1145-A to "HIGH." (See fig. 4.) Watch the tube of Indicator BC-929-A for an indication that the signal from the signal generator is received, when the "HIGH RCVR OSC" tuning shaft is turned, with a fibre screwdriver. This adjustment is reached through an opening in the front panel of Radio Receiver and Transmitter BC-800-A. (See fig. 2.) Adjust the receiver "GAIN" control until a signal of about $\frac{1}{2}$ maximum amplitude is observed on the display tube.

(e) Adjust the "HIGH RCVR OSC" control on Radio Receiver and Transmitter BC-800-A for maximum signal amplitude on the indicator screen.

(f) Unlock the screw with the locking washer under each of the receiver tuning adjustments "1-2-3," located on the front panel of Radio Receiver and Transmitter BC-800-A.

(g) Tune receiver tuning adjustments "1-2-3" for maximum signal on the display tube.

Note

If no signal appears on the display tube, move the signal generator close to the receiver antenna for preliminary adjustment.

(b) Repeat steps (d) and (f) for an accurate setting.

(i) Tighten locking nuts on the receiver tuning adjustments, marked "1-2-3." Check that the setting does not shift as these nuts are tightened.

(j) Tune Signal Generator I-96-B to the high frequency calibration point as determined in paragraph 2b(4)(g) this section, and place it 25 feet in front of the airplane.

(k) Adjust the "RCVR OSC" tuning shaft marked "HIGH" for maximum signal on the indicator screen with the "HIGH-LOW" switch on the control box set to the "HIGH" position. Do not change the receiver tuning adjustments. Repeat the above procedure for an accurate setting. After the correct setting has been ob-

tained, do not change the "HIGH RCVR OSC" tuning adjustment.

(l) Set Signal Generator I-196-B to the low frequency calibration point as determined in paragraph 2b(4)(b) this section. With the "HIGH-LOW" switch on the control box in the "LOW" position, adjust the "RCVR OSC" tuning shaft marked "LOW" for maximum output on the indicator screen. Repeat the above procedure for an accurate setting. After the correct setting has been obtained, do not change the "LOW" "RCVR OSC" tuning control.

(m) Place Signal Generator I-196-B approximately 50 to 75 feet to the right of the airplane at an angle of 45 degrees from the center line. The signal generator must always be set with the side nearest the nameplate facing the airplane. The signal amplitude on the right side of the display tube of Indicator BC-929-A should be greater than the signal on the left side.

(n) Repeat step (m) with the signal generator to the left side. The received signal should now have great-

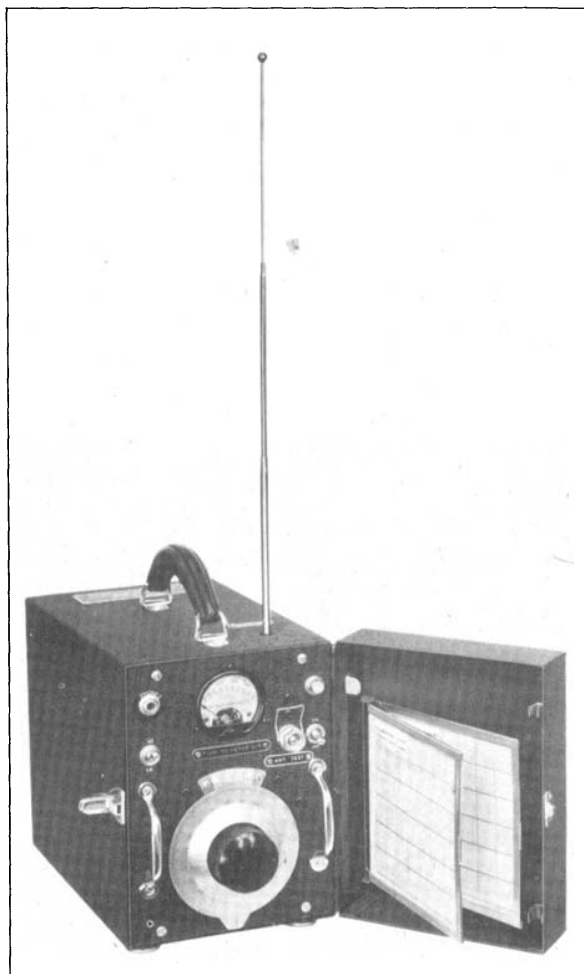

Figure 20 — Frequency Meter BC-906-D

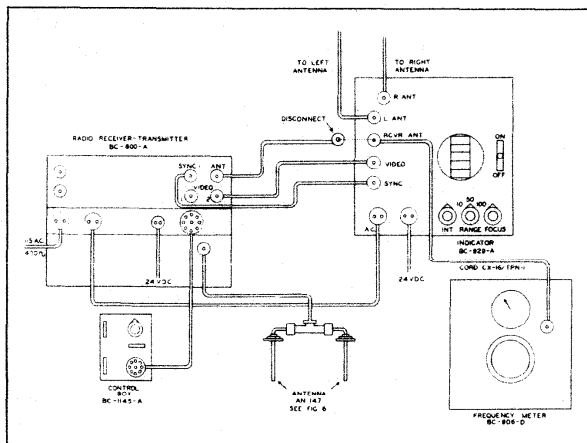

Figure 21 — Cording Diagram of Transmitter Frequency Check

er amplitude on the left side of the trace line on Indicator BC-929-A.

(o) In order to determine whether or not the receiver antenna systems are properly balanced, set Signal Generator I-196-B approximately 25 feet in front of, and directly in line with, the center of the airplane. The signal generator must be set with the side nearest the name plate facing the airplane. If the signals are of equal amplitude on both sides of the time base line of the cathode-ray tube, the receiving antenna system is satisfactorily balanced for homing. This test must be made with the aircraft in an open area to avoid signal reflections from nearby objects. The propellers on each side of the aircraft must be placed in similar positions.

(4) TRANSMITTER FREQUENCY CHECK.

Note

The antenna load often affects the transmitter frequency. Therefore, the transmitter frequency should be adjusted after the equipment has been installed in the airplane.

(a) Obtain the frequency code number on the chart of Frequency Meter BC-906-D, which corresponds to the transmitter frequency, from the Communications Officer-in-Charge or from the "Handbook of Maintenance Instructions for Radio Set SCR-729-A or SCR-729-AZ and Test Equipment IE-56-A."

(b) Connect the terminal marked "RCVR ANT" on Indicator BC-929-A to the terminal marked "ANT. TEST" on Frequency Meter BC-906-D. (See fig. 21.)

Note

Cord CX-16/TPN-1 is used to make this connection and is furnished as auxiliary equipment. Cord CX-16/TPN-1 may be made by placing Plug PL-259 or PL-259-A and coupling

MC-277 on the ends of a 3-foot length of coaxial cable.

(c) Place the "DI-IR" switch in the standby (mid) position. Make sure there is an antenna load or 50-ohm dummy. Place the "ON-OFF" switches on Control Box BC-1145-A and Indicator BC-929-A in the "ON" position. Allow 3 minutes for the set to warm up.

(d) Place the "DI-IR" switch on the control box to the "DI" position.

(e) Turn the "ON-OFF" switch on the frequency meter to the "ON" position and rotate the dial for the greatest dip of the needle. The dial position (number) should be that corresponding to the correct transmitter frequency.

(f) If it is found that the transmitter frequency is incorrect, set the dial of the frequency meter to the position (number) corresponding to the desired transmitter frequency.

(g) Using a fibre screwdriver, adjust the transmitter frequency for the greatest dip of the needle on the frequency meter. The transmitter tuning adjustment is reached through a window marked "TRANS FREQ" on the front panel of Radio Receiver and Transmitter BC-800-A.

(5) INDICATOR CALIBRATION CHECK (NAUTICAL MILES).

(a) To check the calibration of Indicator BC-929-A, a signal from Range Calibrator BC-949-A (see fig. 22) is fed to Indicator BC-929-A which is adjusted at each of the three ranges for correct calibration.

(b) Disconnect Plug PL-259 from the socket marked "SYNC" on Indicator BC-929-A and connect it to the socket marked "SYNC INPUT" on Range Calibrator BC-949-A. (See fig. 24.)

(c) Connect Plug PL-259 on one end of Cord

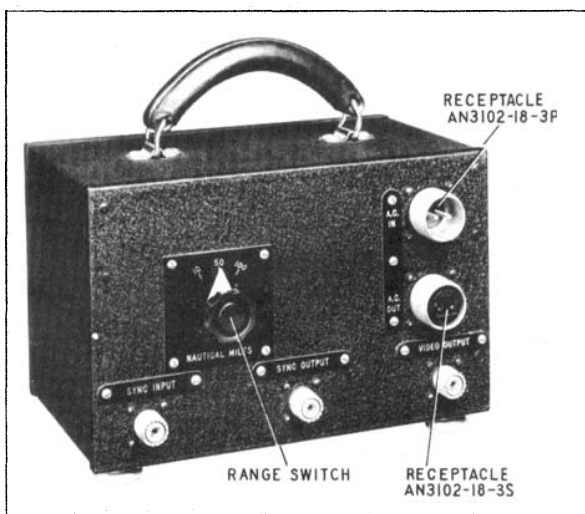

Figure 22 — Range Calibrator BC-949-A

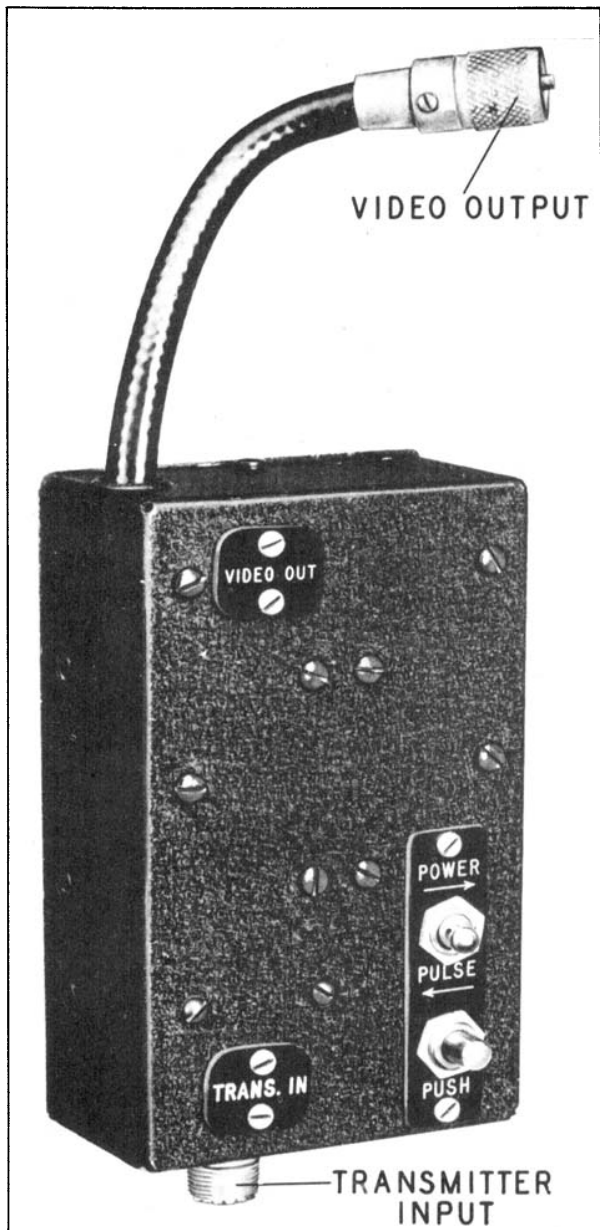

Figure 23 — Indicator BC-936-A

CD-800 to the socket marked "SYNC OUTPUT" on Range Calibrator BC-949-A and connect Plug PL-259 on the other end to the socket marked "SYNC" on Indicator BC-929-A.

(d) Disconnect Plug PL-259 from the socket marked "VIDEO" on Indicator BC-929-A.

(e) Using the other cord, CD-800, connect the socket marked "VIDEO" on Indicator BC-929-A to the socket marked "VIDEO OUTPUT" on Range Calibrator BC-949-A.

(f) Disconnect the power plug from its socket on Indicator BC-929-A and connect it to the socket marked "A.C.-IN" on Range Calibrator BC-949-A. Connect one end of Cord CD-799 to the remaining socket on Range Calibrator BC-949-A and the other end to the power socket on Indicator BC-929-A.

Note

Make sure proper load is connected to "TRANS. ANT." (See fig. 24.)

(g) With the "DI-IR" switch in the mid-position, turn on Radio Set SCR-729-A and allow 3 minutes for warm-up. Place the "DI-IR" switch on Radio Control Box BC-1145-A to the "DI" position and set the range switches on Range Calibrator BC-949-A and Indicator BC-929-A to the position marked "10." The display tube of Indicator BC-929-A will now show a wavy line symmetrically located on both sides of the vertical center line. The points used in calibration are the points of minimum horizontal width. For each range there are ten calibration points so the 10-mile range will have two calibration points every 2 miles. (See fig. 17.)

(h) Align the indicator by using the vertical centering control ("VER CENT") on Indicator BC-929-A to place the 2-mile calibration point on the 2-mile horizontal line.

(i) The 8-mile calibration point should then fall on the 8-mile horizontal line. If it does not, make a screwdriver adjustment on the sweep amplitude control, marked "10" (Indicator BC-929-A), until it does.

(j) A slight readjustment of the "VER CENT" control may then be necessary to again align the 2-mile calibration point.

(k) Adjust the sweep duration control, marked "10," so the lines stop when they reach the 10-mile horizontal line.

(l) Turn the range switches on Indicator BC-929-A and Range Calibrator BC-949-A to the 50 position and turn the screwdriver adjustment marked "SWEEP AMPLITUDE" until the 40-mile calibration point lies over the 40-mile horizontal line. Repeat step (k) using "SWEEP DURATION" 50 control. No adjustment of "VER CENT" should be made except on the 10-mile range.

(m) Place range switches on Indicator BC-929-A and Range Calibrator BC-949-A on the 100-mile range and turn the screwdriver adjustments marked "SWEEP AMPLITUDE" until the 80-mile calibration point lies on the 80-mile horizontal line. Repeat step (k) using "SWEEP DURATION" 100 control.

Note

The sweep trace shifts slightly when a different "RANGE" scale is selected. The "VER CENT" control should be adjusted for the range requiring the most accuracy. This will depend on the nature of the mission.

(n) Disconnect Range Calibrator BC-949-A and associated cables from Indicator BC-929-A and reconnect all cable plugs which were removed. In reconnecting the equipment follow the cording diagram, figure 6.

Note

Do not alter "SWEEP DURATION" or "SWEEP AMPLITUDE" adjustments unless actually making adjustments using Range Calibrator BC-949-A.

**(6) INDICATOR CALIBRATION CHECK
AND ADJUSTMENT FOR STATUTE
MILE SCALE.**

(a) Normally, the range scale of the mask over the screen of the cathode ray tube of Indicator BC-929-A is calibrated in nautical miles. However, a mask calibrated in statute miles is provided in an envelope attached to the switching motor inside the indicator.

(b) The procedure for calibrating the statute mile scale is identical to that given for the nautical mile scale except that the lower dotted line is used in place of the 10-2 range line and the upper dotted line is used in place of the 40-8 range line. (See figs. 26-31.)

(7) POWER OUTPUT CHECK.

(a) Check the power output of the transmitter of Radio Receiver and Transmitter BC-800-A by applying the output signal of the transmitter to Indicator BC-929-A through Indicator BC-936-A.

(b) With Radio Set SCR-729-A turned off, disconnect Plug PL-259 from the socket marked "TRANS ANT" on Radio Receiver and Transmitter BC-800-A.

(c) Disconnect Plug PL-259, which is connected to the socket marked "VIDEO" on Indicator BC-929-A, and connect it to the socket marked "TRANS IN" on Indicator BC-936-A.

(d) Connect the cord from Indicator BC-936-A marked "VIDEO OUT" to the socket marked "VIDEO" on Indicator BC-929-A.

(e) Disconnect Plug PL-259 from the socket marked "VIDEO" on Radio Receiver and Transmitter BC-800-A and connect it to the socket marked "TRANS ANT" on Radio Receiver and Transmitter BC-800-A. These changes in cording should arrange the equipment as shown in figure 25.

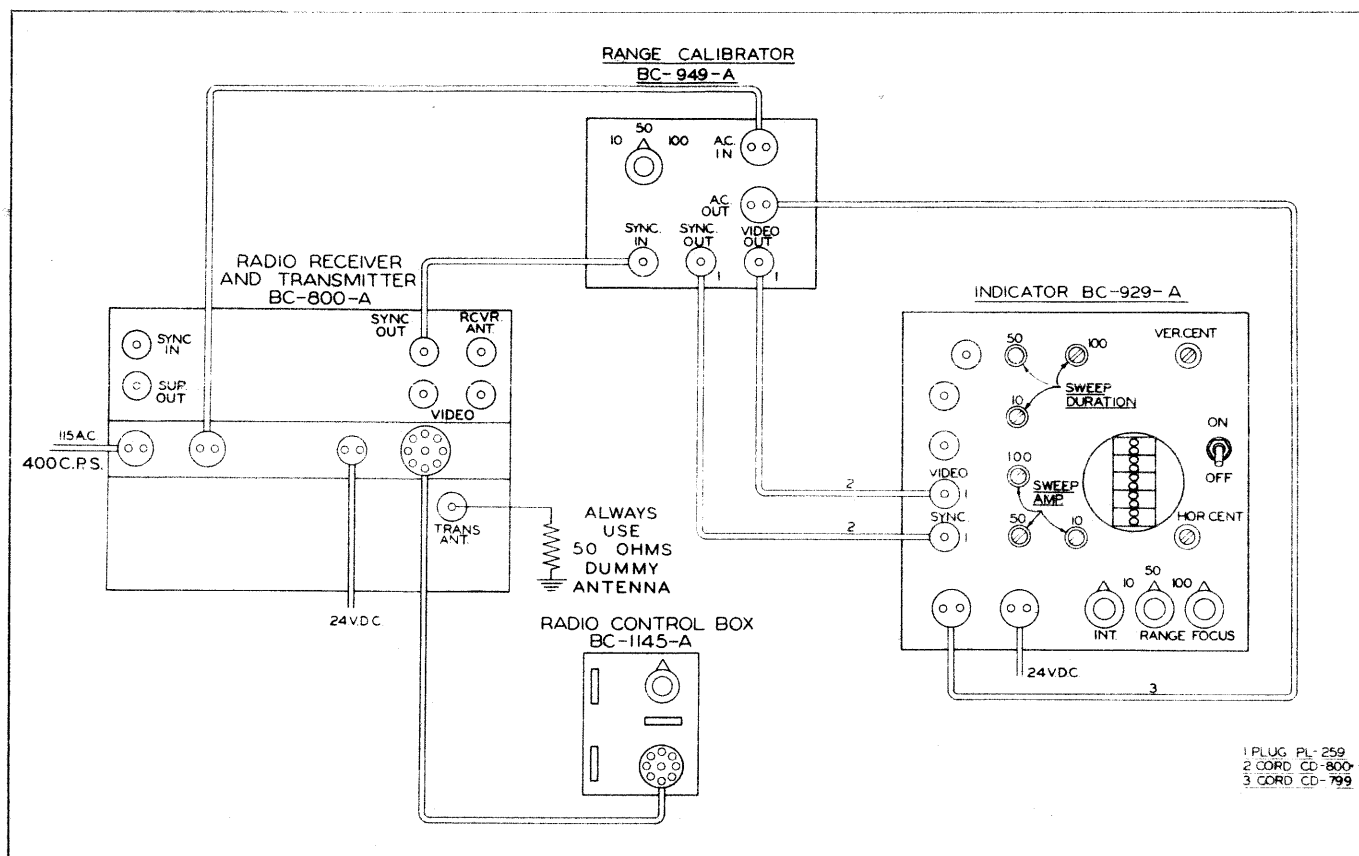

Figure 24 — Indicator BC-929-A Calibration Check — Cording Diagram

Section II
Paragraph 2

RESTRICTED
AN 08-40SCR729-2

(f) Turn on Radio Set SCR-729-A and throw the toggle switch on Indicator BC-936-A to the "POWER" position.

(g) Using the "HOR CENT" control on Indicator BC-929-A shift the base line of the signal to the right-hand vertical line on the screen. (See figs. 14 and 28.)

(h) Turn on Indicator BC-936-A by pressing momentary contact switch marked "PUSH." The transmitter signal will now appear at the zero line on the display tube of Indicator BC-929-A. The tip of the signal should extend at least four and one-half scale divisions to the left as shown in figure 15. This is an indication of minimum allowable power output.

(i) Reset the base line of the signal to the center line of the screen with the "HOR CENT" control as shown in figure 12 or 26.

(j) Throw the toggle switch on Indicator BC-936-A to "PULSE." Press the "PUSH" button on Indicator BC-936-A. The transmitter pulse will now appear on the screen of Indicator BC-929-A as a rectangular pulse as in figure 16 or 30. With the "RANGE" switch of Indicator BC-929-A set at "10," the pulse should have a width of less than half of one vertical division as in figure 16 or 30.

(k) Disconnect Indicator BC-936-A and reconnect the video cable to the video socket of Indicator BC-929-A. Disconnect the other end of the video cable from the "TRANS ANT" socket of Radio Receiver and Transmitter BC-800-A and reconnect to the video socket of the receiver and transmitter. Reconnect "TRANS ANT" cable to "TRANS ANT" socket. The equipment should now check with the cording diagram, figure 6.

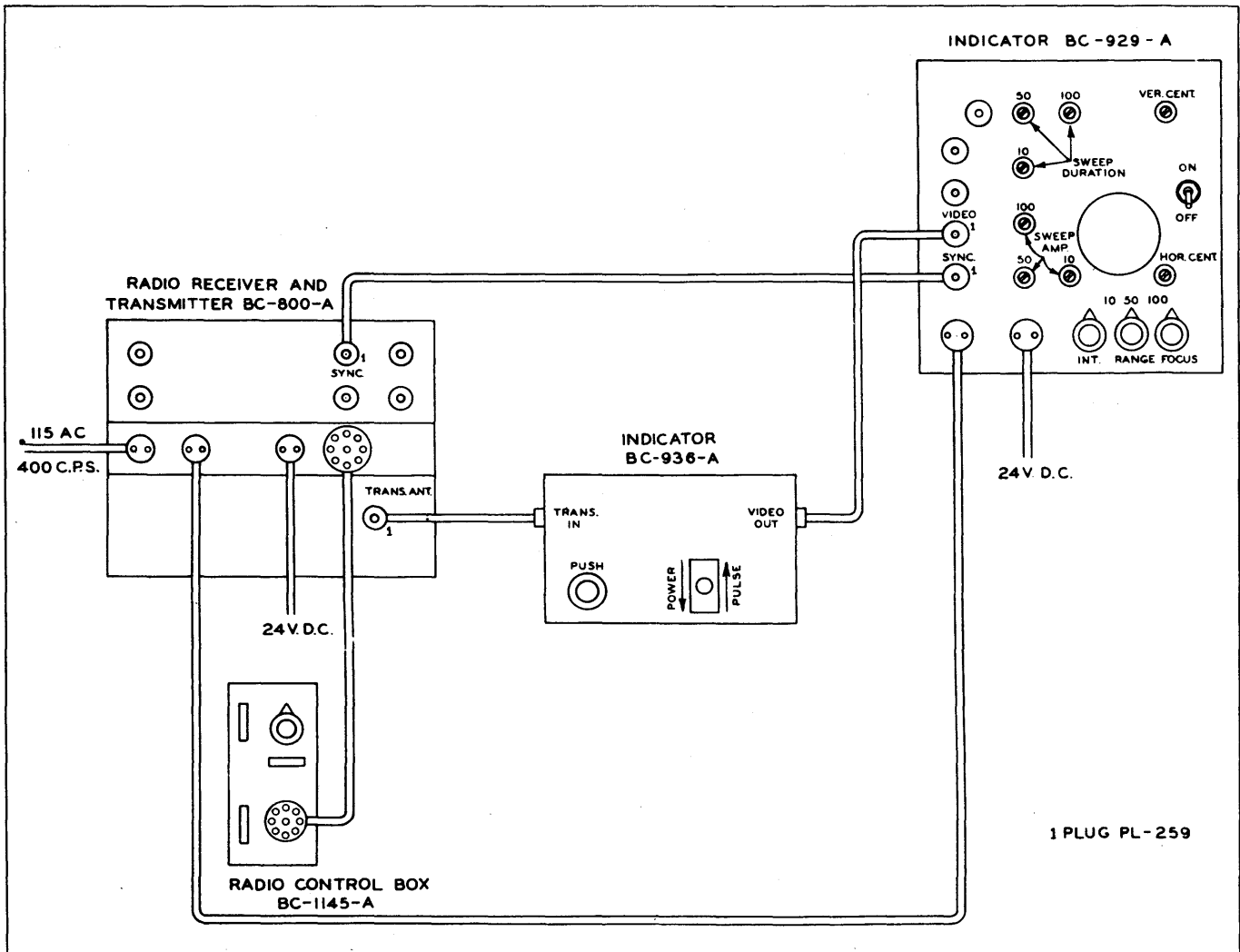

Figure 25 — Power Output Check — Cording Diagram

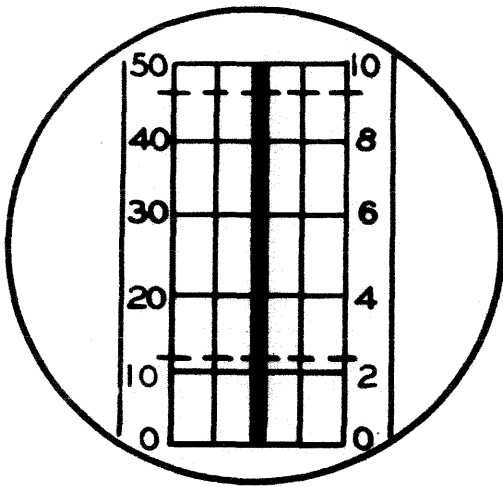

Figure 26 — Sweep Trace (Statute Scale)

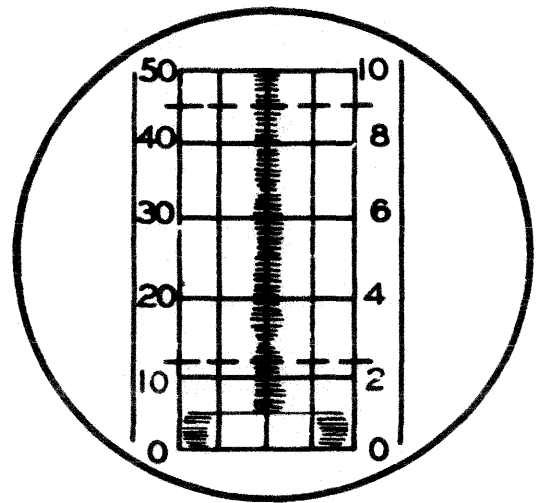

Figure 27 — Hash (Statute Scale)

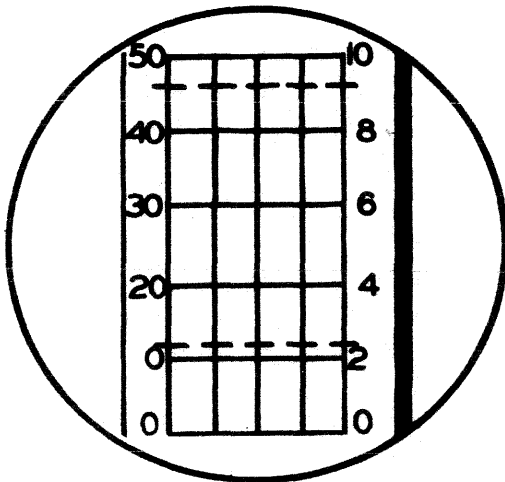

Figure 28 — Sweep Trace (Statute Scale) Set for Power Output Check

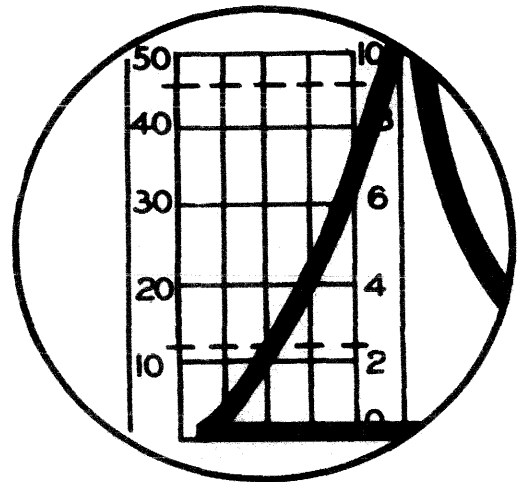

Figure 29 — Power Output Signal (Statute Scale)

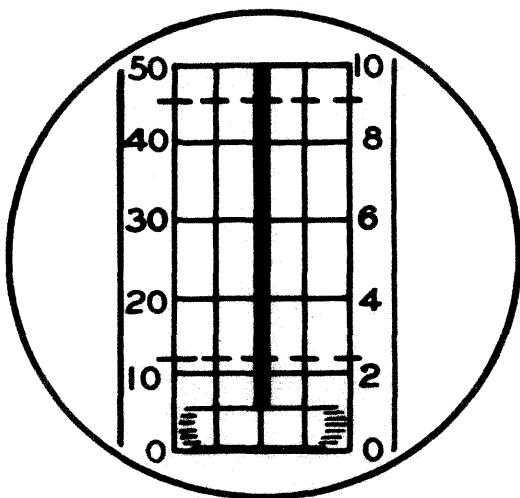

Figure 30 — Pulse Width Signal (Statute Scale)

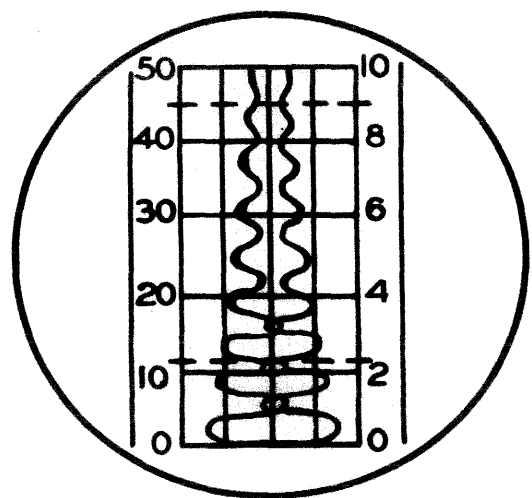

Figure 31 — Calibration Signal (Statute Scale)

**SECTION III
OPERATION**

CAUTION

"TRANS. ANT." socket on Radio Receiver and Transmitter BC-800-A must be connected to a proper load to avoid immediate failure of transmitting tube 2C26 when the power switch on Control Box BC-1145-A is turned on. If the transmitting antenna is not connected, a 50-ohm resistor must be substituted as a dummy load. Connect this resistor from the center conductor of the "TRANS. ANT." socket to the chassis. This resistor is shown in figure 24.

1. STARTING THE EQUIPMENT.

- a. With the "DI-IR" switch on Control Box BC-1145-A in the mid-position, turn "ON-OFF" switches on Radio Control Box BC-1145-A and on Indicator BC-929-A to "ON" positions.
- b. Check that the blower operates.
- c. Wait 3 minutes for warm-up period.
- d. Turn the "DI-IR" switch in "DI" position and the receiver "GAIN" control to maximum clockwise position. Adjust the "FOCUS" and "INTENSITY" controls on Indicator BC-929-A for a clear trace. (See fig. 13.)

- e. Adjust the receiver "GAIN" control on Radio Control Box BC-1145-A to proper level.
- f. Place the "HIGH-LOW" switch to the selected position.

IMPORTANT

Further use of the "HIGH-LOW" switch and the "DI-IR" switch depends upon the nature of the mission.

- (1) If the equipment is to be used for constant operation, set the "DI-IR" switch to the "DI" position.
- (2) If the equipment is to be used for momentary operation, hold the "DI-IR" switch in the "IR" position. It will not remain in this position unless held. A coded message may be sent by use of this switch or, if it is desired to stop the sensing switch on the indicator, the "ON-OFF" switch on the indicator can be turned off.

2. STOPPING THE EQUIPMENT.

To stop the equipment, turn off the "ON-OFF" switches on Indicator BC-929-A and Radio Control Box BC-1145-A.

**SECTION IV
EMERGENCY REPAIR**

1. GENERAL.

- a. After a new installation or a change in equipment, make the installation inspection as discussed in section II, paragraph 1b. Check the transformer tap connections. Make an operation test to secure correct function of components. (Refer to sec. II, par. 2a.)
- b. To prepare for a mission, make a brief installation check. Check and adjust the receiver and transmitter

frequencies.

- c. After each week of average flying time, make a complete installation and operation check. (Refer to sec. II, pars. 1-2.)

2. COMMON TROUBLES AND THEIR CORRECTIONS.

Listed below is a trouble chart giving suggested remedies:

<i>Observation</i>	<i>Trouble</i>	<i>Remedy</i>
Blower motor does not operate	Cord disconnected	Check cord
No spot on screen of Indicator BC-929-A with "INTENSITY" control turned to the extreme clockwise position.	Indicator BC-929-A faulty; cords disconnected or broken	Check all cording. If still faulty replace Indicator BC-929-A
Spot on indicator tube, but no trace line	Faulty cord and connection to the transmitter and receiver	Check the sync cords from Radio Receiver and Transmitter BC-800-A
Hash but no signal	Receiver-transmitter not operating correctly	Replace Radio Receiver and Transmitter BC-800-A
Signal or indicator abnormal	Bad antenna connections	Check antenna cords and connections
	Transmitter output weak or no output	Replace Radio Receiver and Transmitter BC-800-A
	Bad cord connections	Check all connections
	"ON-OFF" switch on Indicator BC-929-A in "OFF" position	Turn the switch to "ON"
	Output from Radio Receiver and Transmitter BC-800-A faulty	Replace Radio Receiver and Transmitter BC-800-A
	Indicator BC-929-A not functioning properly	Replace Indicator BC-929-A

