



GRID DIP METER 'BUILD-IT-YOURSELF' KIT MODEL GD-1U

This instrument is extremely useful in the design, construction and operation of Radio and TV equipment. In particular it can be used for checking resonant frequency of tuned circuits without the necessity for removing components.

Other applications include the alignment of I.F. stages, traps and filters, and various uses in coil winding applications.

Model GD-1U covers 1.8 to 230 Mc/s in five bands, with extension down to 350 Kc/s using additional coil set model 341-U. The compact size allows it to be held close to the circuit under test in one hand, leaving the other hand free for circuit adjustments. It has the additional advantage that it can be used as an absorption wave meter.

A phone socket is provided for listening to "zero beat" against another oscillator in order to determine its frequency. A 500uA panel meter is used for visual indication and a variable sensitivity control is also provided. Five pre-wound plug-in coils are provided for continuous frequency coverage from 1.8 Mc/s to 230 Mc/s.

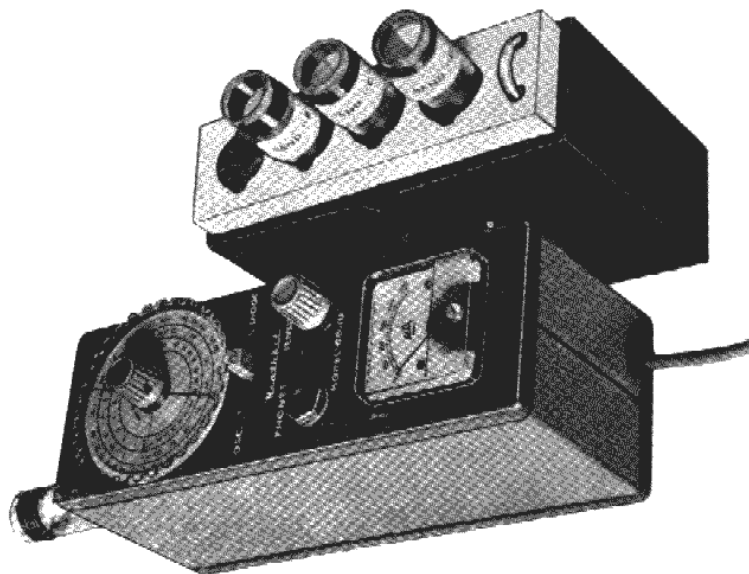

MODEL GD-1U
(Available in kit form or assembled and tested)

SPECIFICATION

- FREQUENCY RANGE :** .. Band A 1.8 to 5.0 Mc/s.
.. Band B 5.0 to 13.0 Mc/s.
.. Band C 13.0 to 35.0 Mc/s.
.. Band D 35.0 to 100 Mc/s.
.. Band E 90 to 230 Mc/s.
- RESONANCE INDICATION :** Visual. 500µA 1½" square moving coil meter.
Aural. Using headphones.
'Phone socket fitted on the front panel.
- FRONT PANEL CONTROLS :** Tuning.
Sensitivity/on-off switch.
Absorption wavemeter/
GDO switch.
- POWER REQUIREMENTS :** 200-250 volts, 5 watts,
45-60 c/s AC.
- POWER SUPPLY :** Double wound transformer, selenium rectifier.
- COILS :** 5 plug-in coils are supplied in a coil box. The formers are of polystyrene and are fitted with nickel plated pins.
- ADDITIONAL COILS** Optional extra coil set 341-U extends range down to 350 kc/s.
- VALVE :** EC92.

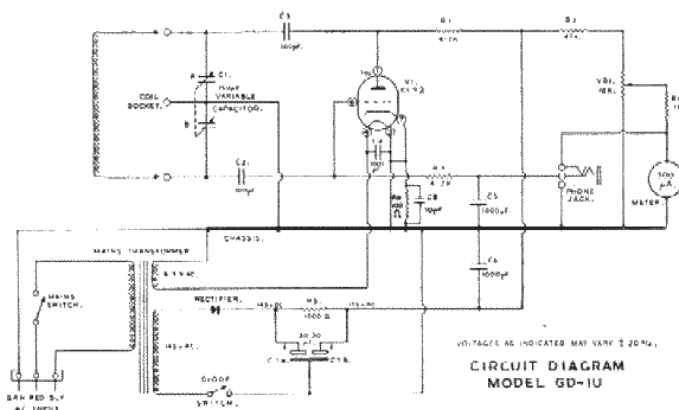

(In accordance with our policy of keeping abreast with technical developments, we reserve the right to modify this circuit wherever desirable).

- FINISH :** Front and rear panel. Dark grey enamel with white printing.
.. .. Case. Ash grey wrinkle.
- DIMENSIONS :** 7½" x 2½" x 3".
- WEIGHT :** 3¼ lb. (net) 4¼ lb. (packed)

A Catalogue of the full British Heathkit range is available free from:—



GLOUCESTER, ENGLAND
Member of the Schlumberger Group, including the Heath Company, manufacturers of
**THE LARGEST-SELLING ELECTRONIC KIT-SETS
IN THE WORLD**