

PHILIPS



HF Generator 100kHz-110MHz

PM5324

9452 053 240.1

9499 450 05511

730801/1/01



PHILIPS



Instruction manual

HF Generator 100 kHz - 110 MHz **PM5324**

9452 053 240.1



9499 450 05511

730801/1/01

Important

In correspondence concerning this instrument please quote the type number and the serial number as given on the type plate at the rear of the instrument.

Contents

1.	GENERAL	6
1.1.	INTRODUCTION	6
1.2.	TECHNICAL	7
1.2.1.	HF-Generator	7
1.2.2.	Modulation	7
1.2.3.	Calibration	8
1.2.4.	Supply	8
1.2.5.	Temperature range	9
1.2.6.	Mechanical data	9
1.3.	ACCESSORIES	9
1.3.1.	Included as standard	9
1.3.2.	Optional	9
1.4.	DESCRIPTION OF THE BLOCK DIAGRAM	10
2.	DIRECTIONS FOR USE	12
2.1.	INSTALLATION	12
2.1.1.	Position	12
2.1.2.	Connection to the mains	12
2.1.3.	Earthing	12
2.2.	OPERATION	13
2.2.1.	Switching on	13
2.2.2.	Adjusting the frequency	13
2.2.3.	Adjusting the mode	13
2.2.4.	Application	13
2.3.	APPLICATION EXAMPLES	17
2.3.1.	Introduction	17
2.3.2.	Preparation	17
2.3.3.	Static measuring method	18
2.3.4.	Dynamic measuring method	22
2.3.5.	Frequency marks	25
3.	SERVICE DATA	26
3.1.	CIRCUIT DESCRIPTION	26
3.1.1.	HF oscillator	26
3.1.2.	Amplitude modulator	27
3.1.3.	Frequency modulator	27
3.1.4.	1 kHz Oscillator	28
3.1.5.	Sweep signal generator and blanking pulse former	28
3.1.6.	Calibrator	28
3.1.7.	Range indication	30
3.1.8.	Supply	30

3.2.	GAINING ACCESS TO AND REPLACING OF PARTS	31
3.2.1.	Cabinet panels	31
3.2.2.	Scale lamp, illumination of indicator	31
3.2.3.	Tuning capacitor	31
3.2.4.	Unit 1, push-buttons, unit 3	31
3.2.5.	Tuning FREQUENCY, drive, scale and indicator	31
3.3.	MAINTENANCE	32
3.4.	SURVEY OF CHECKING AND ADJUSTING POINTS	33
3.5.	CHECKING AND ADJUSTING	34
3.5.1.	Supply	34
3.5.2.	1 kHz Voltage	34
3.5.3.	Sawtooth voltage	34
3.5.4.	Square-wave voltage	34
3.5.5.	Amplitude modulator, compensation of the modulation voltage	35
3.5.6.	HF signal	35
3.5.7.	Blanking the fly-back during wobbling	37
3.5.8.	Sweep width	37
3.5.9.	Checking the modulation	40
3.5.10.	Calibration	41
3.6.	LIST OF PARTS	42
3.6.1.	Mechanical	42
3.6.2.	Electrical	47

FIGURES

1. Zero beat indication	11
2. Block diagram	11
3. Adaptation mains transformer	12
4. Front view	14
5. Rear view	14
6. Block diagram of the static measuring method	17
7. Block diagram of the dynamic measuring method	17
8. Dummy aerial	17
9. Connection of the indicator to an output with a low output impedance	18
10. Connection of the indicator to an output with a high output impedance	18
11. Static adjustment of an a.m. receiver	19
12. Checking and adjusting the band-pass curve of the ratio detector of an f.m. receiver	20
13. Checking and adjusting the band-pass curve of the i.f. band filter of an f.m. receiver	20
14. Alternately damping and adjusting the primary and secondary circuits	21
15. Idealized band-pass curve of the i.f. amplifier of a TV set	21
16. Dynamic adjustment of an f.m. receiver	23
17. Frequency scale	23
18. IF band-pass curve	23
19. Discriminator curve	24
20. IF band-pass curves	24
21. Generating frequency markers	25
22. Mixing circuit	25
23. Low-pass filter	25
24. Frequency mark	25
25. HF-Oscillator	26
26. Amplitude modulator	27
27. Crystal oscillator	29
28. Band-pass curve indicator	30
29. Functioning of the blanking of the fly back	34
30. Measuring set-up to determine the frequency sweep and the symmetry	38
31. Measuring set-up to determine the frequency sweep and the symmetry	38
32. Measuring set-up for representing a modulation trapezium	41
33. Front view with item numbers	44
34. Bottom view	44
35. Top view	44
36. Left-side view	44
37. Scale drive	45
38. Oscillograms of unit 1	52
39. Printed wiring board 1	53
40. Demounting the push-button unit on unit 1	53
41. Printed wiring board 2	54
42. Oscillograms of unit 2	54
43. Printed wiring board 3	55
44. Circuit diagram PM 5324	59

TABLES

1. Adjusting table h.f. oscillator	36
2. Checking table frequency modulator	40
3. Checking table for a.m. and f.m.	40
4. Settings of oscilloscope and PM 5324	55

1. GENERAL

1.1. Introduction

AM-FM-Generator PM 5324 produces unmodulated and modulated HF-Signals. It is very useful in radio-servicing and in technical education.

The frequency range is from 0.1 MHz to 110 MHz in 9 sub-ranges.

Fine adjustment of the frequency is effected on a large, illuminated, easy-to-read linear scale. The range which is in use and the scale to be read is indicated by means of LEDs. The output voltage is electronically stabilised and is continuously adjustable.

The AM-FM-Generator may also be used in the frequency range from 150 MHz to 220 MHz, e.g. in band III as a test generator for television sets, or as a generator in the frequency range for taxi-transmission.

With an internal X-tal oscillator the frequency of the generator can be checked and, if necessary, adjusted.

1.2. Technical data

General

- Alternative voltages are stated as r.m.s. values.
- Only values with tolerances and or numerical values are guaranteed.
- Deviations (in % or ppm) apply to the adjusted value.
- Temperature coefficients apply within temperature range.
- All specifications are met after a warming-up time of 30 minutes.

1.2.1. HF-GENERATOR

Frequency range	0.1 MHz up to 110 MHz 9 ranges: 0.1 ... 0.3 MHz 0.3 ... 1 MHz 1 ... 3 MHz 3 ... 10 MHz 10 ... 30 MHz 30 ... 80 MHz 75 ... 110 MHz 0.4 ... 0.5 MHz 10.3 ... 11.1 MHz
Scale	6 linear, illuminated scales
Accuracy	< 1.5 % in the ranges 0.1 ... 80 MHz < 1 % in range 75 ... 110 MHz < 0.5 % in range 0.4 ... 0.5 MHz < 0.2 % in range 10.3 ... 11.1 MHz < 0.1 % on calibrated points
Long-term stability	< 0.1 % at: – nominal operating conditions – mains voltage variations +10 %, –15 % – measured over 7 hours
Temperature coefficient	$\leq 5.2 \cdot 10^{-4} / ^\circ\text{C}$
Output HF OUT	Connection : BNC connector Output voltage: 50 mV into 75 Ω , at unmodulated signal
Frequency-response	0.1 MHz ... 110 MHz : ≤ 3 dB 0.4 MHz ... 0.5 MHz } ≤ 0.2 dB 10.3 MHz ... 11 MHz }
Attenuator	≥ 60 dB, continuous for frequencies < 15 MHz: ≥ 60 dB

1.2.2. MODULATION

Modes	unmodulated : all ranges AM : all ranges FM : range 75 ... 110 MHz and 10.3 ... 11.1 MHz Wobble : ranges 75 ... 110 MHz, 0.4 ... 0.5 MHz and 10.3 ... 11.1 MHz
AM, internal	Modulation frequency: 1 kHz (sine wave) Modulation depth : 30 %

AM, external	Input : via BNC connector LF IN Modulation depth : > 70 % Modulation coefficient : 0.2 V/10 % AM 3 dB-Band width : 20 Hz ... 20 kHz Input impedance : 10 k Ω
FM, internal	Modulation frequency: 1 kHz (sine wave) Sweep (Δf) : 25 kHz, at 10.7 MHz and 97 MHz (dependent on frequency)
FM, external	Input : via BNC connector LF IN Sweep (Δf) : 75 kHz, at 10.7 MHz and 97 MHz Modulation coefficient : 0.2 V/7.5 kHz at 10.7 MHz and 97 MHz (dependent on frequency) 3 dB-Band width : 20 Hz ... 60 kHz Input impedance : 10 k Ω
Wobble	Wobulating sweep ($2\Delta f$): range 0.4 MHz ... 0.5 MHz, 0 ... 40 kHz at 460 kHz range 75 MHz ... 110 MHz, 0 ... 600 kHz at 97 MHz range 10.3 MHz ... 11.3 MHz, 0 ... 600 kHz at 10.7 MHz Wobble frequency: 25 Hz (sawtooth)
1 kHz Output	BNC connector; combined with sweep output Voltage : 2 V Frequency : 1 kHz (sine wave) Impedance : 1 k Ω
Sweep output	BNC connector; combined with 1 kHz output Voltage : 10 V _{p-p} Frequency : 25 Hz (saw tooth) Impedance : 1 k Ω

1.2.3. CALIBRATION

Frequency	10 MHz } spectrum with at least 10 harmonics 1 MHz } for every frequency 0.1 MHz }
Error	< 0.02 %

Frequency distance of the calibration points	Range	Distance
	.13 MHz	0.1 MHz
	.3 ... 1 MHz	0.1 MHz
	1 ... 3 MHz	1 MHz
	3 ... 10 MHz	1 MHz
	10 ... 30 MHz	10 MHz
	30 ... 80 MHz	10 MHz
	75 ... 110 MHz	10 MHz
	.45 MHz	0.1 MHz
	10.3 ... 11.1 MHz	0.1 MHz

Zero beat indication By moving coil instrument, illuminated when button CAL. is pressed

1.2.4. SUPPLY

Nominal mains voltage	220 V Also possible 110 V, 128 V, 202 V and 238 V
Mains voltage deviation	+10 %, -15 %
Frequency	48 ... 60 Hz
Consumption	11 W, 13 VA

1.2.5. TEMPERATURE RANGE

Reference temperature	+25 °C
Temperature tolerance range	+5 °C ... +40 °C
Storage temperature	-40 °C ... +70 °C

1.2.6. MECHANICAL DATA

Dimensions	Height : 192 mm
	Width : 287 mm
	Depth : 290 mm
Weight	5 kg

1.3. Accessories

1.3.1. INCLUDED AS STANDARD

- Mains cable
- Directions for use

1.3.2. OPTIONAL

- Coax cable BNC → 2 x 4 mm PM 9072
- Coax cable BNC → BNC, 75 Ω PM 9075
- Impedance transformer PM 9537

1.4. Description of the block diagram

The frequency of the generator is determined by an HF-oscillator the amplitude of which is electronically stabilised. Frequency ranges are selected with push-button MHz. Within the selected range the frequency can be adjusted continuously by control FREQUENCY.

A frequency-modulator provides voltage-controlled frequency modulation of the HF-oscillator - e.g. for wobbling purposes - in the ranges 75 MHz ... 110 MHz, 0.4 MHz ... 0.5 MHz and 10.3 MHz ... 11.1 MHz ().

In the amplitude-modulator the amplitude of the HF-signal can be modulated in all frequency ranges and the HF-signal blanked during fly-back at mode WOB (.

The HF-output stage amplifies the power of the HF-signal, the amplitude of which is adjustable continuously with attenuator HF AMPLITUDE.

The output signal is available at connector HF OUT; the output impedance amounts to 75 Ω .

If button CAL. is pressed an X-tal controlled calibration oscillator produces harmonics to check the calibration of the scale. The markers are at a distance of 10 MHz, 1 MHz or 0.1 MHz, depending on the selected frequency range.

In the mixer the signals of the HF-output stage and of the calibration oscillator are mixed. The low-frequency signal which is obtained at approximately equal frequencies of both signals is amplified, limited, rectified and indicated by a moving coil meter. If the HF-frequency control is set at a calibration frequency, the indicator, at exactly equal frequencies, indicates a sharp, limited minimum between two full scales. (Fig. 1).

A 1 kHz-sine wave signal, produced by a 1 kHz oscillator, is used for amplitude- or frequency modulation and selected by push-buttons AM or FM. The 1 kHz signal is also available at connector 1 kHz/SWEEP OUT if button WOB has not been depressed. If button AM EXT. or FM EXT. has been depressed the HF-signal can be modulated by an external signal supplied to connector LF IN.

If button WOB has been depressed, a saw-tooth signal, produced by a saw-tooth generator, is supplied to the frequency modulator. The sweep of the frequency can be adjusted by potentiometer SWEEP WIDTH. At the same time the saw-tooth signal with constant amplitude is available at connector 1 kHz/SWEEP OUT.

A square-wave pulse derived from the saw-tooth signal blanks the output stage during fly-back.

The supply section delivers two stabilised direct voltages (-12 V and -18 V) and an alternating voltage for illumination of the scale.

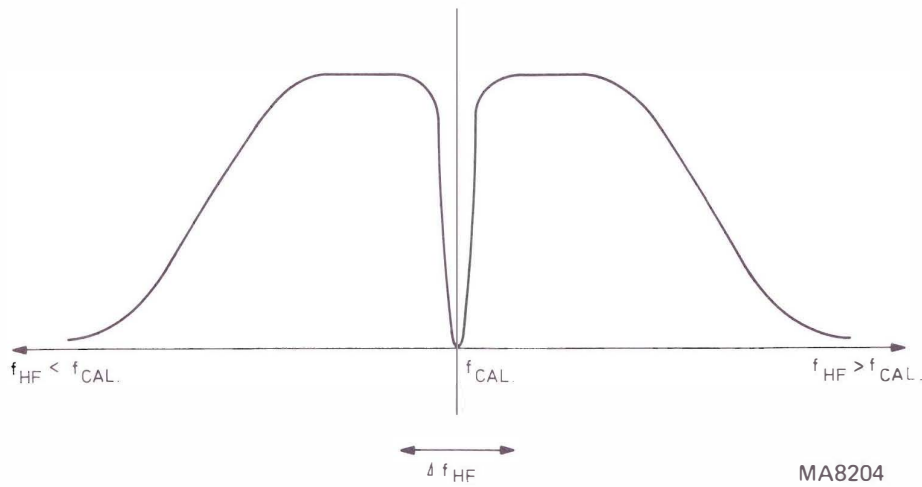

MA8204

Fig. 1. Zero beat indication

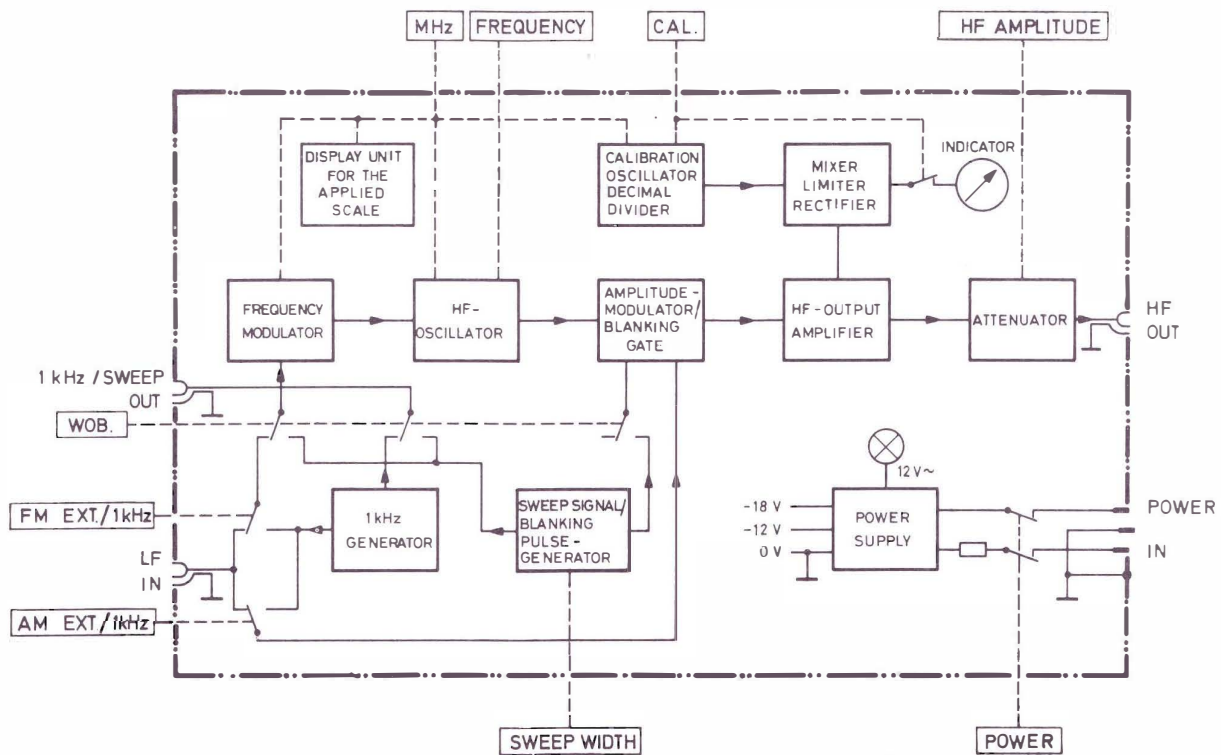

Fig. 2. Block diagram

MA8205

2. DIRECTIONS FOR USE

2.1. Installation

2.1.1. POSITION

The instrument may be used in any position except on its rear end. Make sure that the instrument is not exposed to excessive heat.

2.1.2. CONNECTION TO THE MAINS

The instrument must have a.c. supply only. On delivery, it is set for a mains voltage of 220 V. Setting for a different mains voltage is done as follows:

- Remove the left screw of the handle bar and take off the left side-plate.
- Change the primary connections of the mains transformer according to Fig. 3, a diagram of which is in the inside of side-plate.
- Change the mains voltage indication-plate at the rear.
- Refit the handle bar.
- Connect up the instrument.

2.1.3. EARTHING

The instrument must be earthed in accordance with the local safety regulations. The mains cable supplied is provided with an earth core which is connected to the earth contacts of the mains plug. If the instrument is connected to a mains socket with earth contacts, the cabinet is automatically earthed.

The circuit earth of the instrument and the chassis-connection of the BNC-connectors are at chassis potential.

Earthing the instrument via the chassis-connection of the BNC-connectors is not permitted.

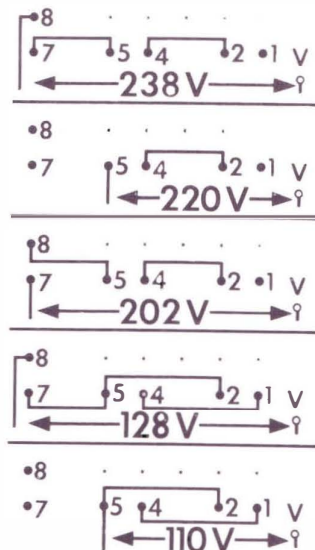

Fig. 3. Changing the primary connections of the mains transformer

2.2. Operation

2.2.1. SWITCHING ON

- Connect the instrument to a mains socket with earthing contacts.
- Switch on by means of switch POWER; the scale illumination lights up and a white field in the button-cap shows that the mains switch is on.

2.2.2. ADJUSTING THE FREQUENCY

- Select the required frequency range with one of the range buttons MHz; the corresponding range-scale is indicated by a LED at the left side of the scale window.
- Adjust to nominal frequency with potentiometer FREQUENCY.

2.2.3. ADJUSTING THE MODE

The mode is selected by depressing one of the 6 buttons in the left row of buttons.

If no button has been pressed the generator supplies an unmodulated HF-signal with the adjusted frequency and amplitude.

Buttons CAL., AM/EXT., AM/1 kHz, FM/EXT. and FM/1 kHz unlock each other automatically, thus only one button can be depressed at a time.

Button WOB. may be unlocked by pressing the button a second time, independently of the other buttons.

The mode-buttons may be combined with the frequency-range buttons according to the table given below.

Range button (MHz)	Mode button (selectable)					extra
	CAL	AM	FM	WOB	WOB + AM	
.1 – .3	X	X				
.3 – 1	X	X				
1 – 3	X	X				
3 – 10	X	X				
10 – 30	X	X				
30 – 80	X	X				
75 – 110	X	X	X	X		X
.4 – .5	X	X		X		X
10.3 – 11.1	X	X	X	X		X

2.2.4. APPLICATION

2.2.4.1. Unmodulated HF-signal generator

- Depress the required range button MHz.
- The selected range scale is indicated by a LED.
- Set the pointer at the required frequency by means of potentiometer FREQUENCY.
Not marked frequency values should be interpolated between two marks.
- If necessary, calibrate the frequency at the nearest calibration-mark according to sub-para 2.2.4.5.
- Unlock the mode-buttons (left row of buttons).
- Apply the HF-signal, available at BNC connector HF OUT, across a cable to the object to be measured (see accessories, chapter 1.3.).
- Adjust the required output voltage with potentiometer HF AMPLITUDE.

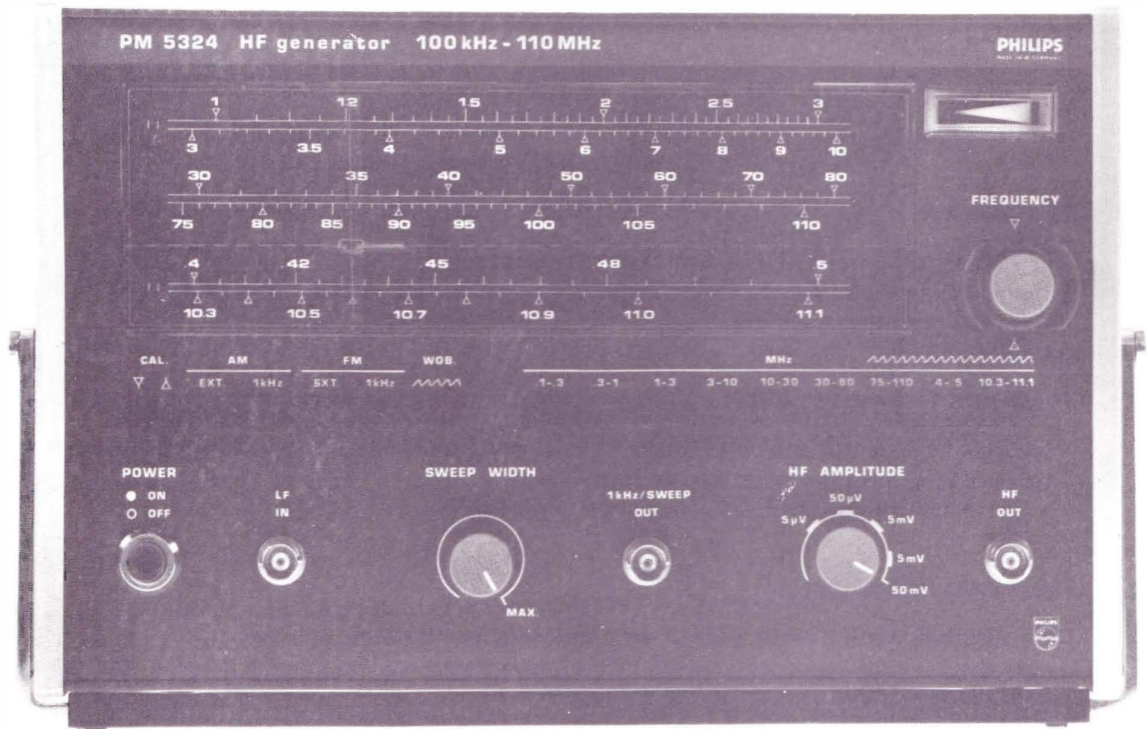

Fig. 4. Front view

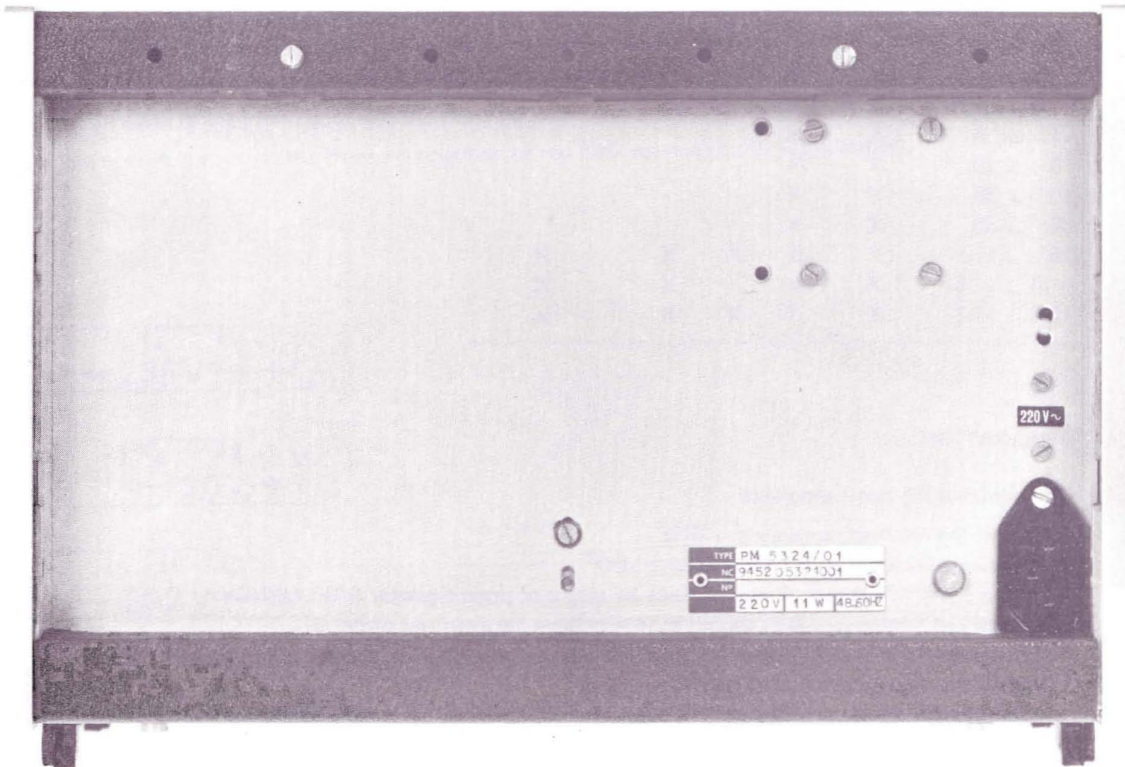

Fig. 5. Rear view

2.2.4.2. Amplitude-modulated (AM) HF-signal generator

Internal

- Preliminary adjustment according to chap. 2.2.4.1. .
- Press button AM/1 kHz. The HF-signal is modulated in amplitude by 30 % at an internal frequency of 1 kHz.
- For indications on checking and adjusting, see the individual checking and adjusting procedures for the object to be measured or chapter 2.3. .

External

- Preliminary adjustment according to chap. 2.2.4.1. .
- Press button AM/EXT.
- Supply the modulation voltage to connector LF IN; maximum 16 V peak-peak, maximum d.c. level ± 12 V.
- External modulation frequency 20 Hz ... 20 kHz.
- Adjust the modulation depth by the amplitude of the modulation voltage; voltage necessary 0.2 V/10 % amplitude-modulation.
- For indications on checking and adjusting, see the individual checking and adjusting procedures for the object to be measured or chapter 2.3.

2.2.4.3. Frequency-modulated (FM) HF-signal generator

Internal

- Press buttons 75 - 110 or 10.3 - 11.1 MHz.
The selected range scale is indicated by a LED.
- Set the pointer at the required frequency by potentiometer FREQUENCY.
Not marked frequency values should be interpolated between two marks.
- If necessary, calibrate the frequency at the nearest calibration-mark according to sub-para 2.2.4.5. .
- Press button FM/1 kHz; the HF-signal is modulated in frequency by 1 kHz and a frequency sweep of about 25 kHz.
- Apply the signal, available at BNC connector HF OUT, across a cable to the object to be measured.
(see accessories, chapter 1.3.).
- Adjust the required output voltage by means of potentiometer HF AMPLITUDE.
- For indications on checking and adjusting, see the individual checking and adjusting procedures for the object to be measured or chapter 2.3.

Note

When using harmonics the frequency sweep is multiplied by the order-number of the harmonics.

External

- Preliminary adjustment according to chap. 2.2.4.3. .
- Press button FM/EXT.
- Supply the modulation voltage to BNC connector LF IN; maximum input voltage 70 V peak-peak.
- Adjust the external modulation frequency; 20 Hz ... 60 kHz.
- Adjust the modulation sweep with the external voltage; necessary voltage 0.2 V/7.5 kHz sweep (maximum sweep 75 kHz).
- If necessary, supply a multiplex-signal to BNC connector LF IN.
- For indications on checking and adjusting, see the individual checking and adjusting procedures for the object to be measured or chapter 2.3.

2.2.4.4. Wobble generator

- Press range-button 75 ... 110 or 10.3 ... 11.1 MHz.
The selected range-scale is indicated by a LED.
- Set the pointer to the required frequency by potentiometer FREQUENCY.
Not marked frequency values should be interpolated.
- Press button WOB.
- Connect BNC-connector 1 kHz/SWEEP OUT to the X-input of an oscilloscope.
- Adjust the X-amplitude of the oscilloscope.
- Apply the wobbled signal across a cable to the object to be tested.

- Set the band-pass curve at the middle of the picture with potentiometer FREQUENCY.
- Adjust the height of the band-pass curve with potentiometer HF AMPLITUDE.
- Adjust the width of the band-pass curve with potentiometer SWEEP WIDTH.
- Check the band-pass curve; if necessary, correct it. The effect of an adjustment can be determined immediately on the band-pass curve.

Note

When using harmonics the frequency sweep is multiplied by the order number of the harmonics.

Determining the band width

By defined shifting in the horizontal direction the band width (at 70 % of the height of the picture) can be determined as follows:

- Position the point of intersection, e.g. of the right edge of the band-pass curve and a fictitious horizontal line at 70 % of the height of the curve on a prominent point on the graticule by means of potentiometer FREQUENCY.
- Read the frequency at the scale and note the value.
- Shift the band-pass curve horizontally with potentiometer FREQUENCY so that the second edge is positioned at the same fictitious point of intersection (at 70 % of the height of the picture) as in the first adjustment.
- Read the frequency; the difference between the two frequencies is the band width.

Note

Use a d.c. indicator (oscilloscope or meter) so that the base line is horizontal and undistorted at a large wobulating-sweep.

2.2.4.5. Calibration

The calibration points are indicated on the scale by the symbol ∇ or Δ . A moving coil meter, which is illuminated at calibration mode, serves as indicator.

Checking

If a very accurate HF-signal, e.g. of 21.5 MHz is needed, this can be checked as follows:

- Switch on the instrument and wait at least 30 minutes for it to warm up.
- Depress range-button 10 - 30 MHz; the diode alongside the top scale will light up.
- Depress button CAL.; the indicator will light up. If necessary, unlock button WOB. .
- Set the scale pointer to that calibration mark (∇ at mark .2) which is nearest to the nominal value of 21.5 MHz.
- Set the scale pointer exactly on the minimum which lies between two full-scale deflections of the indicator.
- Check, that the line of the scale pointer corresponds to the calibration mark.

Calibration

If the line of the scale pointer is not exactly over the calibration mark calibrate as follows:

- Set the scale pointer exactly on the calibration mark.
- Hold the largest knob of control FREQUENCY with one hand.
- Adjust the smaller knob -- against the resistance of the slipping clutch -- to obtain the required minimum (zero beat) between two maxima.
- Release the large button.
- Adjust for exact zero beat.
- Check that the line of the scale pointer corresponds to the calibration mark. Repeat the calibration procedure, if necessary.

2.2.4.6. 1 kHz-Generator

- Release all push-buttons, especially button WOB.
- The 1 kHz-signal, with an amplitude of $2 V_{r.m.s.}$, is available at BNC-connector 1 kHz/SWEEP OUT.

2.3. Application examples

2.3.1. INTRODUCTION

Usually the band-pass curve of a certain test object is measured statically i.e. point by point.

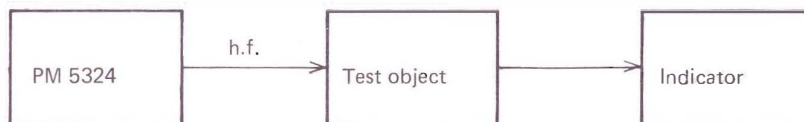

Fig. 6. Block diagram of the static measuring method

The static method gives very reliable results but is much too time-absorbing. As mostly only the shape must be determined and not the absolute values of the band-pass curve, the so-called dynamic method (wobbling) is preferred.

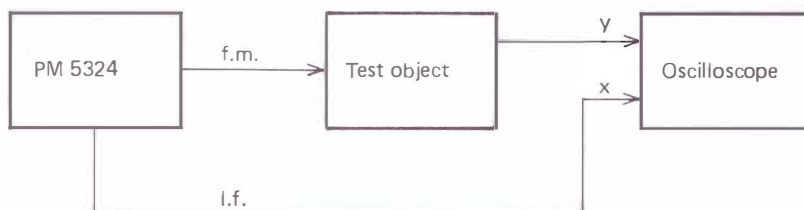

Fig. 7. Block diagram of the dynamic measuring method

2.3.2. PREPARATIONS

2.3.2.1. Connection to the mains

- Connect h.f.-generator PM 5324 according to para. 2.1.2. of the directions for use.
- The test object should be connected to the mains via a separating transformer. Only **one** instrument may be connected to this transformer at the same time. When measuring at all mains receivers or TV sets a separating transformer **must** be used.
- Connect the chassis of the test object to a proper earth.
- Avoid double earthing of the measuring set up.

2.3.2.2. Connection of the signal

The test object may be connected to the h.f.-generator via the cable mentioned below. These cables are optionally available.

- Measuring cable BNC → 4 mm plugs, PM 9536.
- Measuring cable BNC → BNC, PM 9075.
- In the f.m. band, impedance transformer PM 9537 must be used to adapt the output impedance of the generator to the input impedance of the test object.
- In the a.m. band the dummy aerial of Fig. 8 may be used to imitate the impedance of an aerial.

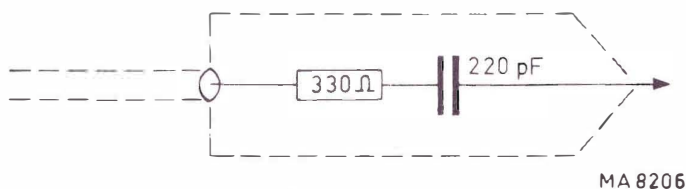

Fig. 8. Dummy aerial

2.3.2.3. Warming-up time

To ensure a good frequency accuracy and stability it is recommended to switch on the generator half an hour before adjustment is started.

2.3.2.4. Switching-off the AGC voltage

To prevent incorrect measuring results it is necessary to switch off the AGC*-voltage of the receiver; it should be replaced by a fixed adjusted voltage. A power supply (e.g. PE 4818) or a battery, to which a potentiometer of about $1\text{ k}\Omega$ is connected in parallel, may be used as a voltage source.

The connection point and the level of the voltage refer to the service documentation of the TV set. If the set has a delayed AGC, it is also possible to measure correctly, only if the input signal supplied is so small that the AGC does not operate yet.

2.3.2.5. Documentation of instruments

The data given should be completed with the corresponding checking and adjusting procedure of the relevant receiver.

2.3.3. STATIC MEASURING METHOD

When the measurements are performed following the static method, the test object is checked point by point. The connecting line of these points results in the band-pass curve. Depending on the output circuit the indicator (output voltage meter) must be connected according to Fig. 9 or 10.

Measuring range of indicator: $3\text{ V}\sim$
(if necessary, select a lower or higher range).

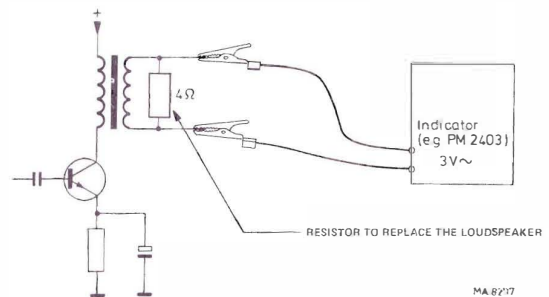

MA 8277

Fig. 9. Connection of the indicator to an output with a low output impedance

Control settings of the receiver

Volume : average value
Bass : maximum
Treble : maximum
Bandwidth : minimum

Measuring range of indicator about $100\text{ V}\sim$
(if necessary, select a lower or higher range).

If several outputs are available, the indicator should be connected to the bass channel.

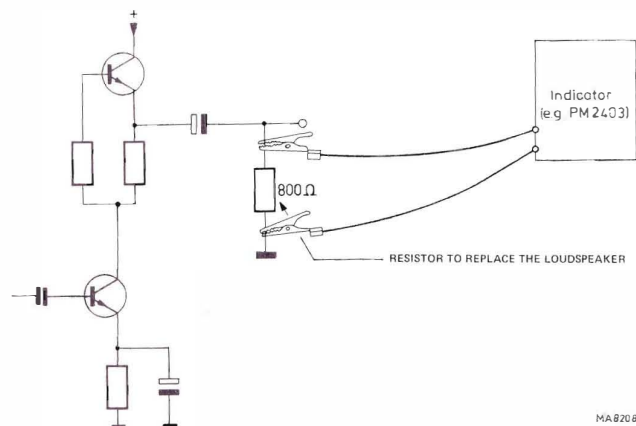

MA 8208

Fig. 10. Connection of the indicator to an output with a high output impedance

AGC = Automatic gain control

2.3.3.1. Checking and adjusting the band-pass curve of a.m. receivers

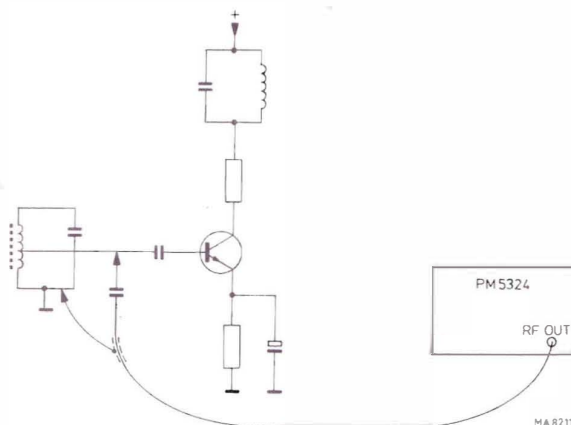

Fig. 11. Static adjustment of an AM receiver

2.3.3.1.1. I.F. band-pass filters

- Connect the h.f. output of the PM 5324 to the connection point indicated in the trimming table of the receiver via a 30 nF capacitor.
- Adjust the frequency of generator PM 5324 to the intermediate frequency of the receiver.
- The output voltage should be as large as possible.
- Tune the receiver to the short wave end.
- Set the receiver to medium wave.
- If the receiver has a ferroceptor, short-circuit the medium-wave ferroceptor coil.
- Screw out the cores or trimmers of the i.f. band filters (note the trimming table of the documentation).
- Adjust the adjusting elements of the i.f. band-pass filters so that the connected indicator shows maximum deflection, in the sequence indicated in the trimming table.

2.3.3.1.2. I.F. rejector and absorption circuits

- Connect the h.f. output of the generator to the aerial input of the receiver via the dummy aerial of Fig. 8.
- Adjust the output voltage of the generator to maximum.
- Switch the receiver to medium wave.
- If the receiver has a ferroceptor, short-circuit the medium wave ferroceptor coil.
- Screw out the cores of the i.f. rejector- and absorption circuit.
- Adjust the cores so that the indication shows minimum deflection.

2.3.3.1.3. RF and oscillator circuits

- Connect the h.f. output of the generator to the aerial input of the receiver via the dummy aerial of Fig. 8.
- Set the receiver to the wave range to be adjusted.
- Tune the receiver and the generator to the frequency to be adjusted.
- Adjust the cores and/or trimmers of r.f. and oscillator circuits to maximum deflection of the indicator.
- If necessary, repeat the adjusting procedure for every wave range at the long- and short wave end.

2.3.3.2. Checking and adjusting the band-pass curve of f.m. receivers

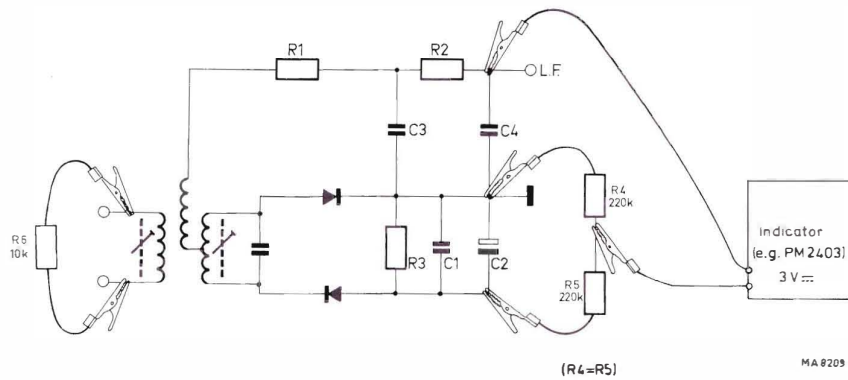

Fig. 12. Checking and adjusting the band-pass curve of the ratio detector of an f.m. receiver

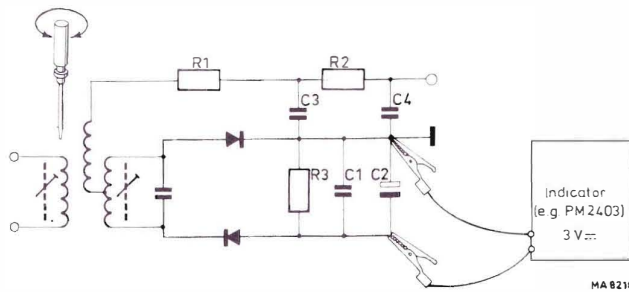

Fig. 13. Checking and adjusting the band-pass curve of the IF band filter of an f.m. receiver

2.3.3.2.1. IF band-pass filters

- Set the volume control to minimum
 - Set the tuning at the long wave end
 - Set the receiver to f.m.
 - Screw out the cores of the i.f. band-pass filters as far as possible; if necessary note the trimming table
 - Connect h.f. generator PM 5324 to the connection point indicated in the service documentation of the receiver via the dummy aerial
 - Adjust h.f. generator PM 5324 to the i.f. frequency
 - Connect the indicator according to Fig. 14
 - Adjust the core of the primary circuit (Fig. 14) of the ratio detector to maximum deflection of the indicator
 - Terminate the primary circuit of the ratio detector with a resistor of approx. $10\text{ k}\Omega$ (R6, Fig. 12). Adjust the core of the secondary circuit to minimum deflection of the indicator, which is connected according to Fig. 12. Repeat the adjustment.
 - Adjust the cores of the other i.f. band-pass filters in the sequence indicated in the service documentation of the receiver.
- The circuits of a band-pass filter which are not adjusted should be terminated with a resistor of approx. $10\text{ k}\Omega$ during the adjustment of a circuit of the band-pass filter (Fig. 14).

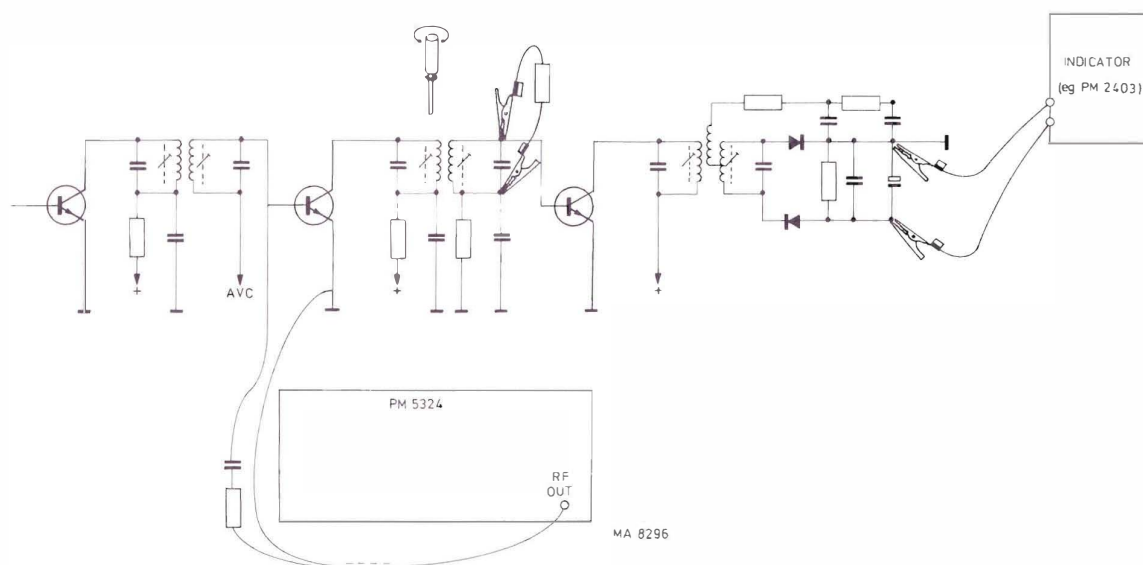

Fig. 14. Alternately damping and adjusting the primary and secondary circuits

2.3.3.2.2. RF and oscillator circuits

- Connect the indicator according to Fig. 14
- Connect the h.f. generator to the f.m. aerial input via impedance transformer PM 9537
- Set the volume control of the receiver to minimum
- Set the receiver to f.m. (VHF)
- Adjust the pointer to the mark on the dial given in the tuning table of the receiver-documentation
- Set the receiver and the h.f. generator to the frequency indicated in the tuning table of the receiver
- Adjust the cores of the h.f. and oscillator circuits to maximum deflection of the indicator in the sequence mentioned in the tuning table.

2.3.3.3. Checking and adjusting at TV sets

2.3.3.3.1. General

The i.f. amplifier of a TV set must meet several requirements:

- the band-pass curve should have a correcting effect on the frequency response curve of the transmitter signal, in which the low frequencies have the advantage with respect to the high frequencies. This implies, among others, that the carrier of the picture signal has to be attenuated by a factor 2 (Fig. 15).
- The sound carrier must be attenuated too: in inter-carrier receivers 12 to 20 times (f_2), in separated carrier receivers 200 times (f_3).
- finally, complete suppression must take place of the sound carrier in the adjacent higher channel (f_4) and of the image carrier in the adjacent lower channel (f_5).

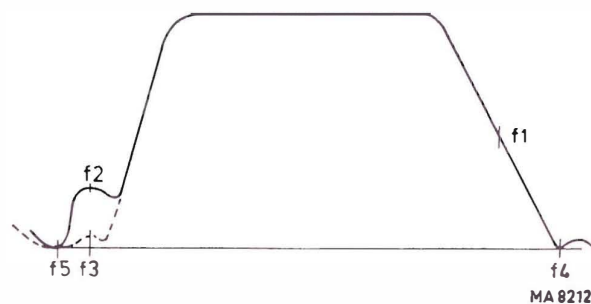

$$A_{f1} = \frac{A_f}{2}$$

$$A_{f2} = \frac{A_f}{12 \div 20}$$

$$A_{f3} = \frac{A_f}{200}$$

$$A_{f4} = A_{f5} = \frac{A_f}{800}$$

Fig. 15. Idealized band-pass curve of the i.f. amplifier of a TV set

2.3.3.3.2. Preparations

- Connect the TV set to the mains via a separating transformer
- Connect the chassis of the TV set to a proper earth
- Settings of h.f. generator PM 5324
 - Depress range button 30 - 80 MHz
 - Depress button AM 1 kHz
 - Connect the h.f. generator to the measuring point indicated in the service documentation.
The screening of the cable to the chassis should be as short as possible
 - Set control HF AMPLITUDE to maximum
- Connect the indicator according to the data given in the documentation of the TV set
- Settings of the TV set
 - Set the channel selector to a free channel or to a position between two channels.
By this the influence of the h.f. band-pass filters in the channel selector on the termination resistor (75Ω) of the h.f. generator is prevented.
 - Set the contrast control to maximum contrast
 - Adjust the AGC voltage to a fixed value. In most of the cases the connection point and the voltage level of the pseudo - AGC voltage are stated in the service documentation of the TV set

2.3.3.3.3. Checking and adjusting

For checking tune the i.f. range with control FREQUENCY (e.g. approx. 31 - 42 MHz).

Read the measured value in intervals and check that the values correspond with the recommended band-pass curve. Bear in mind that the TV set is not overdriven; if necessary, reduce the output voltage of the generator by means of control HF AMPLITUDE.

However, the adjusted output voltage should be constant during the measurement.

If an incorrect adjustment is expected, only adjust those elements corresponding to the test circuit. For this consult the service documentation of the TV set and the relevant damping measures, if necessary.

For more important adjusting faults, it is recommended to carry out a complete adjustment in the sequence given in the documentation and to check the complete band-pass curve again.

The sound channel of a TV set should be checked and adjusted according to 2.3.3.2.

2.3.4. DYNAMIC MEASURING METHOD

2.3.4.1. Principle (Fig. 7)

For this method, a constant frequency-modulated r.f. voltage is necessary. This voltage is fed to the test object which is, in most of the cases, the i.f. amplifier of an a.m. or f.m. receiver.

The frequency-modulated signal and the frequency sweep must cover the entire i.f. range. The demodulator of the receiver will then produce a voltage which is proportional to the gain of the separate frequencies. The form of the amplitude variation corresponds to the band-pass curve of the test object. This voltage is supplied to the input of an oscilloscope (Y-input).

A voltage, which corresponds to the frequency modulation, is fed to the X-input. This sawtooth voltage can be derived from the generator at output SWEEP OUT.

The resulting curve on the screen of the oscilloscope represents the band-pass curve of the test object.

Note

Dynamic adjustments of i.f.- and h.f. circuits of TV sets are impossible as wobbling at this frequencies is impossible with this generator.

2.3.4.2. Checking and adjusting the band-pass curve of an f.m. receiver

2.3.4.2.1. Connection of the measuring instruments (Fig. 16)

- Connect the indicator to resistor R3 of the demodulator via a 0.1-M Ω resistor
- Connect the Y-input of the oscilloscope to resistor R3 via a 0.1-M Ω resistor
- Connect the X-input of the oscilloscope with connector 1 kHz/SWEEP OUT of the PM 5324
- Set the h.f. generator to 10.7 MHz
- Depress button WOB.
- Set the controls of the oscilloscope for horizontal and vertical shift and horizontal amplification in such a way that the line on the screen is symmetrical with respect to the vertical central axis of the graticule. (AB = BC, Fig. 17). Point B in the screen will now represent a frequency of 10.7 MHz.

During adjustment, this setting may not be changed.

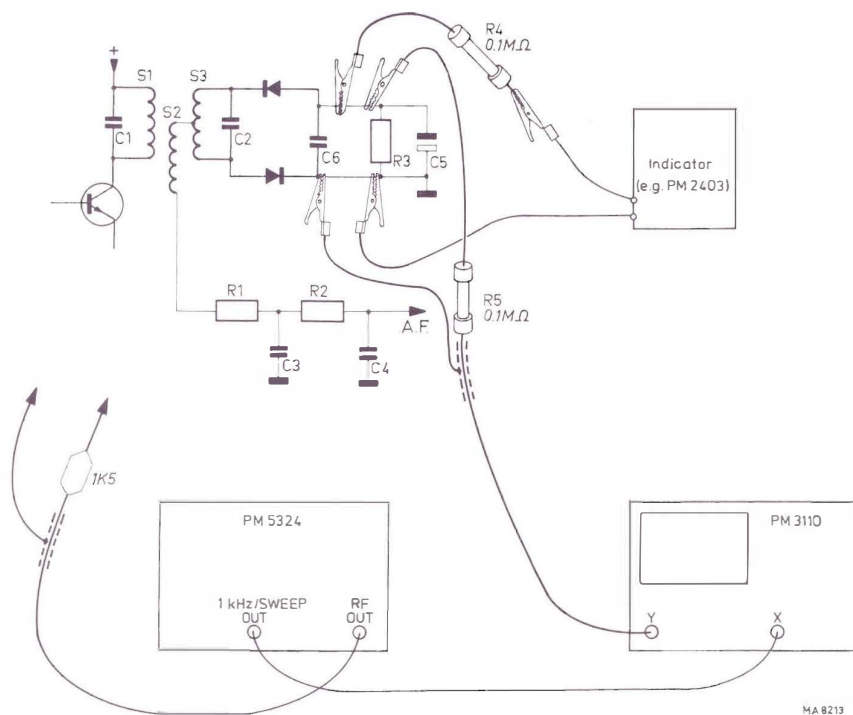

Fig. 16. Dynamic adjustment of an f.m. receiver

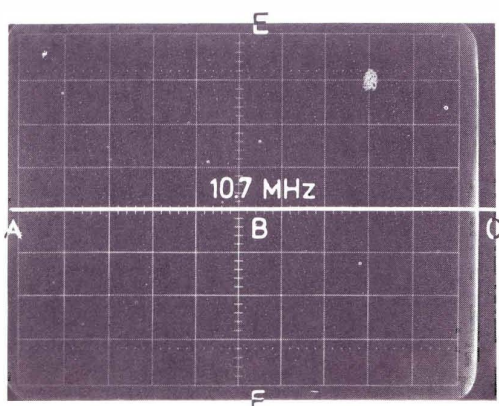

Fig. 17. Frequency scale

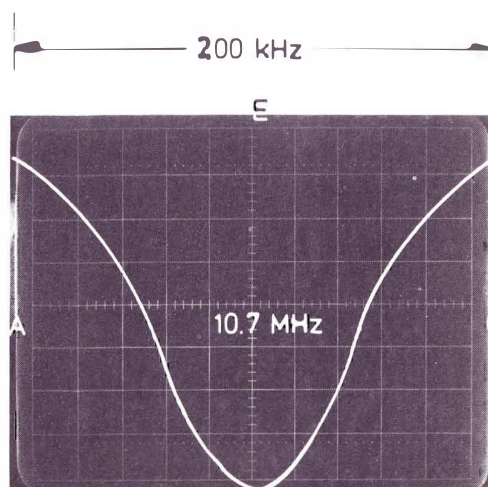

Fig. 18. IF band-pass curve

2.3.4.2.2. IF band-pass filter

- Connect the h.f.-generator to the connection point given in the documentation of the receiver. The earth connection of the h.f.-cable must be connected as short as possible to the point to which the signal is supplied.
- Set the volume control of the receiver to minimum.
- Set the tuning to the long wave end.
- Set the receiver to f.m.
- Screw out the cores of the i.f. band-pass filters as far as possible; note the adjusting procedure, if necessary.
- Unsolder the electrolytic capacitor in the ratio detector (C5, Fig. 16).
- Adjust the core of the primary circuit of the ratio-detector to maximum and symmetry of the band-pass curve, so that the top of the curve at 10.7 MHz is on line EF (Fig. 18).
- Solder the electrolytic capacitor (C5, Fig. 16) again.
- Set the volume control of the receiver to maximum.
- Adjust the core of the secondary circuit of the ratio detector to maximum deflection of the indicator.
- Check the discriminator curve
 - Connect the oscilloscope to C4/R2 (Fig. 16)
 - The zero passage of the band-pass curve should be in the centre of the picture (Fig. 19)
 - The centre of the straight part of the curve should be on line EF (Fig. 19)
 - If the curve has an asymmetrical or non-linear shape, repeat the procedure from 2.3.4.2.2.
- Unsolder the electrolytic capacitor (C5, Fig. 16) again
- Adjust the cores of the other band-pass filters to maximum height of the curve in the sequence indicated in the trimming table (Fig. 20, curve I). The band-pass curve must always be symmetrical with respect to mid-screen (EF, Fig. 20)
- Checking the a.m. suppression
 - Solder the electrolytic capacitor (C5, Fig. 16) again
 - Press button AM/1 kHz
 - The picture on the oscilloscope shows a sinusoidal modulation. The amplitude of this modulation lies between zero (in the middle of the discriminator curve) and a certain value (at the end of the straight part of the curve). The a.m. suppression is sufficient, if the amplitude at the ends is smaller than 1/10 of the height of the curve.

2.3.4.2.3. RF-, IF and oscillator circuits

- Connect the indicator across resistor R3 of the ratio detector via a resistor of 0.1 M Ω (R4, Fig. 16).
- Connect h.f. generator PM 5324 to the f.m. aerial sockets via impedance transformer PM 9537.
- Turn the volume control to minimum.
- Set the receiver to f.m.
- Tune to highest frequency.
- Adjust the receiver and h.f. generator to the frequency indicated in the trimming table.
- Adjust the cores of the r.f.-, i.f.- and oscillator circuits to maximum deflection of the indicator in the sequence indicated in the trimming table.

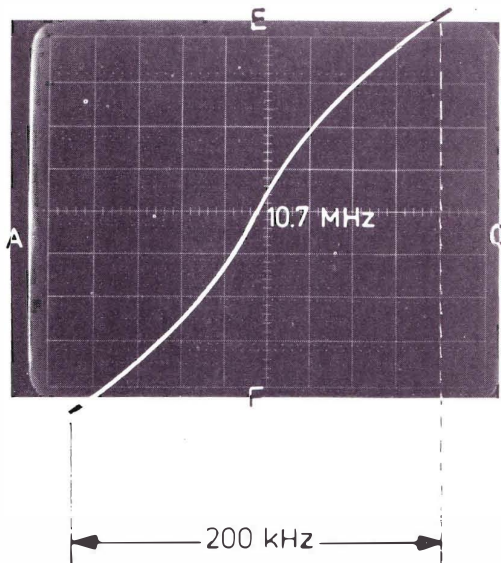

Fig. 19. Discriminator curve

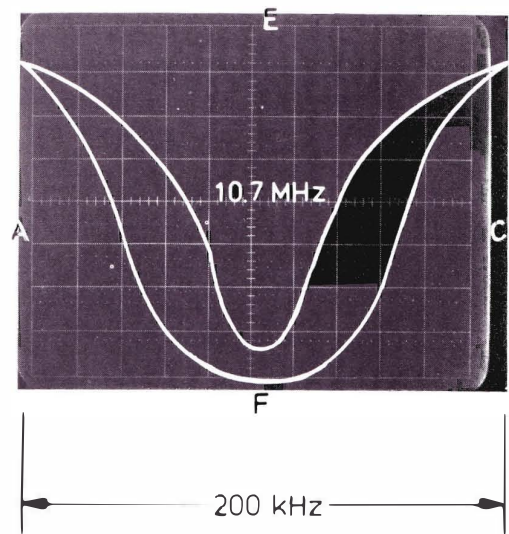

Fig. 20. IF band-pass curves

2.3.5. FREQUENCY MARKS

Marks, which indicate a certain frequency on the band-pass curve, often are important. This can be met if additional equipment is available.

Fig. 21 represents a schematic survey of this principle.

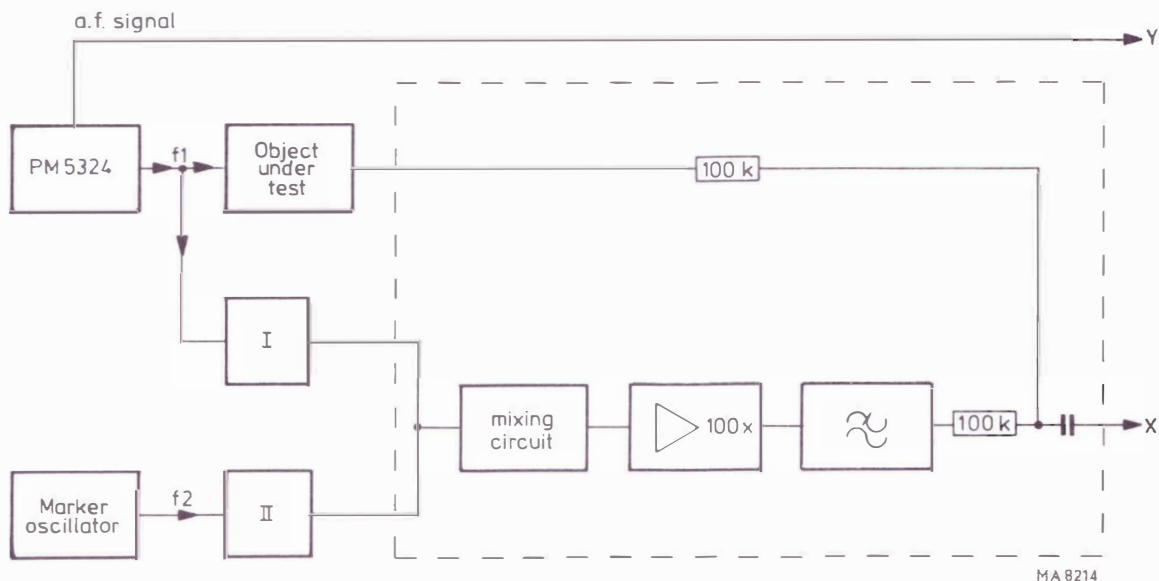

Fig. 21. Generating frequency markers

The signals of both the generators PM 5324 (f_1) and the marker generator (f_2) are applied to a mixing circuit via separator stages I and II. By superposition of the signals at the input of the mixing circuit sum- and difference frequencies ($f_1 + f_2$) and ($f_1 - f_2$) occur at the curved characteristic of the mixing diode due to modulation. Only the difference frequency ($f_1 - f_2$) is amplified by a small-band LF amplifier. This difference signal is applied to a low-pass filter. As soon as both frequencies (f_1 and f_2) approximate sufficiently, the low difference frequencies pass through the low-pass filter. At the moment both frequencies are equal, the difference is zero; provided that they have the same phase and amplitude. If the frequencies deviate again, another l.f. component is formed.

The resulting output pulse is represented in Fig. 24. The marking pulse obtained is added to the output voltage of the test object and is fed to the Y-input of the oscilloscope.

The amplitude of the frequency marks with respect to the band-pass curve can be influenced by changing the amplitude of the marker frequency f_2 or by adjusting the gain of the l.f. amplifier. The frequency marks on the band-pass curve of a test object, obtained in this way can be shifted by varying the frequency of the marker generator.

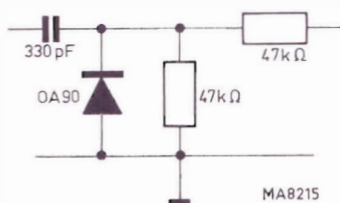

Fig. 22. Mixing circuit

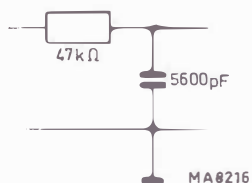

Fig. 23. Low-pass filter

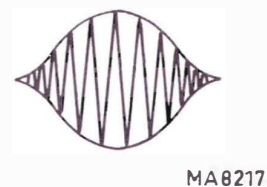

Fig. 24. Frequency mark

3. SERVICE DATA

3.1. Circuit description

3.1.1. HF-OSCILLATOR (Fig. 25)

The frequency of the h.f.-oscillator is determined by the resonant circuit, which can be switched separately to the collector circuit of transistor 301. In conjunction with transistor 302 self-excitation occurs at the oscillation frequency due to positive feedback. The amplitude may be adjusted with potentiometer 612.

Transistors 301 and 302 are coupled via an automatically controlled and regulated current source 305/306. The amplitude of the oscillator is stabilized via this current source. The required control voltage is obtained by rectifying the output-amplitude of separating-amplifier 303/304 by diodes 406 and 407. Diodes 404 and 405 serve for temperature compensation.

The begin- and end frequencies of every range are tuned with adjustable coils and capacitors; adjusting is facilitated by using series and parallel capacitors. With triple tuning capacitor 599, five ranges can be calibrated on two scales; the frequency response of the remaining four ranges is marked on separate scales. Both i.f. ranges - 0.4 ... 0.5 MHz and 10.3 ... 11.1 MHz - have separate scales.

The scale, corresponding with the selected frequency range, is indicated by one of the six LED's 491 ... 496.

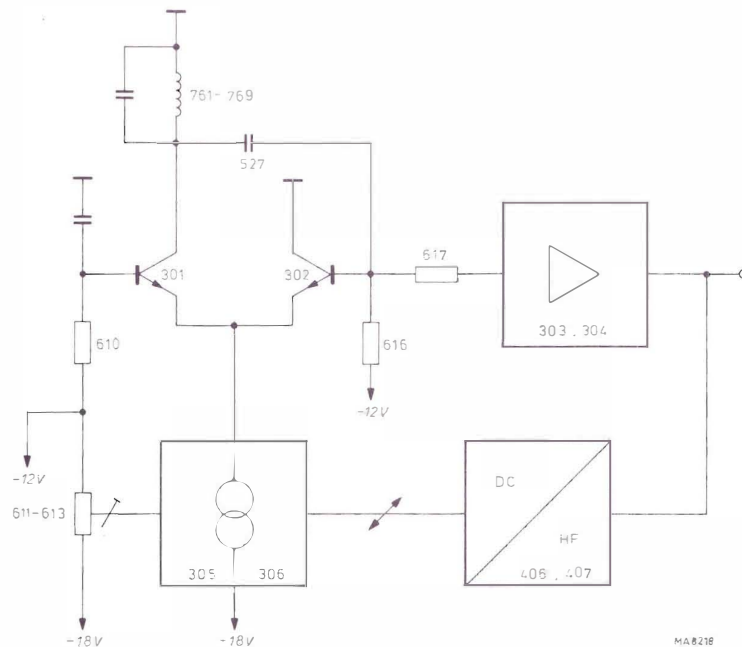

Fig. 25. HF-Oscillator

3.1.2. AMPLITUDE MODULATOR (Fig. 26)

The output signal of the h.f. oscillator is applied to the base of transistor 308 via separating amplifier 303/304 (Fig. 25). Moreover, via stage 307 two components of the modulation voltage are supplied to modulation stage 308. The working point of modulation stage 308 is adjusted with potentiometer 631 so that difference amplifier 308/309 is symmetrical. One component of the modulation voltage is supplied to the emitter of modulation stage 308 via the emitter of transistor 307. The modulation current i_{LF} , which is determined by resistor 626, is supplied by transistors 308 and 309; every transistor supplies half the current.

The current which passes through transistor 308 causes modification of the transconductance (shifting of the characteristic) and thus modulation of the r.f. amplitude. The modulated r.f.-signal is available at resistor 634. The l.f. component across resistor 634 decreasing simultaneously would cause an interference signal superimposed on the modulated signal especially at low h.f.- and at high l.f. frequencies.

This phenomenon is compensated for by supplying the decreasing modulation frequency in anti-phase - available across resistor 624 - to resistor 634 via resistor 625. Resistor 625 is dimensioned in such a way that the passing current amounts to $i_{LF}/2$ thus compensating for the modulation current through resistor 634.

In mode wobble (WOB.) this stage is used for blanking the fly-back. In normal operation diode 408 is blocked; during wobulating the diode becomes conductive by a positive blanking pulse, thus interrupting the h.f.-signal during the fly-back time of the wobble action.

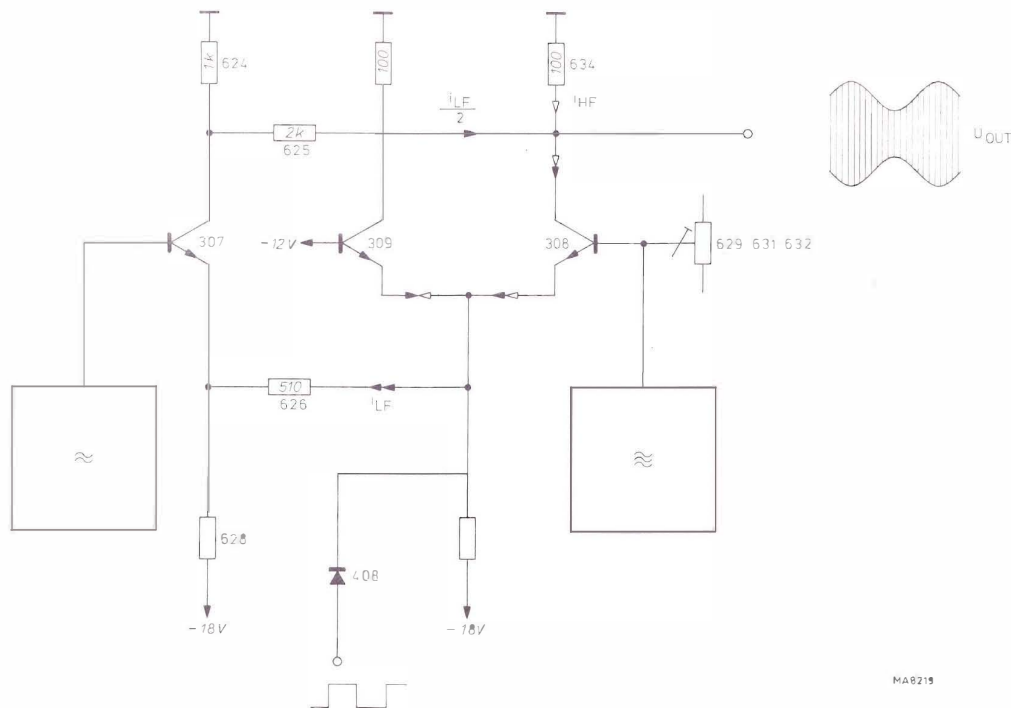

Fig. 26. Amplitude modulator

3.1.3. FREQUENCY MODULATOR

Frequency modulation is effected by voltage-controlled capacitance diodes 401, 403 and 402//411//412. The capacitance diodes influence the oscillating circuit of ranges 75 ... 110 MHz, 0.4 ... 0.5 MHz and 10.3 ... 11.1 MHz via isolating capacitors 520, 522 and 521//539.

The frequency sweep is adjusted with potentiometers 608, 607 and 609. Capacitor 566 raises the high cutoff frequency in the VHF range.

The modulation signal is adapted to resistor-diode network 664 up to 669, 413 and 414 by emitter followers 314 and 315. The network serves to give a pre-distortion of the control voltage of the capacitance diodes to linearise their curve so that the frequency change of the h.f. oscillator is proportional to the controlling modulation voltage.

The capacitance diodes are disconnected from the controlling modulation voltage source by resistors 601, 602 and chokes 771, 772.

3.1.4. 1-kHz OSCILLATOR

The active element of this RC oscillator is integrated circuit 321. The frequency is determined by RC-four pole 626 - 506 / 628 - 507. The amplifier consists of difference amplifier 321/I, the output signal of which is supplied to the mentioned RC four pole via emitter follower 321/II.

The oscillator voltage is also supplied to a rectifier via resistor 622 and capacitor 508.

The rectifier consists of diode 402 and transistor 321/III which is circuited as a diode. This rectifying circuit produces a control voltage to stabilize the amplitude. The output amplitude may be adjusted by means of potentiometer 632.

If button WOB. (803/6) is released, the 1 kHz signal is available at connector 852.

Moreover, the signal is supplied to the amplitude modulator via resistor 621, switch 803/2A and to the frequency modulator via resistor 623, switch 803/5A, -/4A, -/3A, -/2B and -/6A.

3.1.5. SWEEP SIGNAL GENERATOR AND BLANKING PULSE FORMER

The sweep signal generator consists of an emitter-coupled multivibrator 301/302.

The sweep signal is supplied to difference amplifier 304/306, the emitters of which are a.c. coupled. Both stages of the difference amplifier have a constant current source (305 and 307) to obtain a good common mode rejection. With diode 401 the constant current sources are temperature compensated.

The sweep signal for frequency modulation and a sawtooth voltage - phase shifted by 180° - are taken from collector resistors 611 and 616.

The voltage across resistor 611 can be adjusted with potentiometer 602 on behalf of the frequency sweep.

The voltage across resistor 616 is available at connector 1 kHz/SWEEP OUT (852) for external control purposes.

Due to this the modulation voltage at connector 852 increases simultaneously with increasing frequencies.

The blanking pulse, required in mode wobble, is taken from the collector of transistor 302 and applied to transistor 321/IV which functions as a switch. If button WOB. (603/6) is depressed the blanking pulse is supplied to blanking diode 408 via voltage divider 609/610.

3.1.6. CALIBRATOR

The calibrator consists of a calibrating oscillator, a mixer, an LF amplifier with limiter and indicator.

3.1.6.1. Calibrating oscillator

The calibrating oscillator consists of a crystal oscillator and two decimal dividers.

3.1.6.1.1. Crystal oscillator (Fig. 27)

The active elements of the oscillator are Nand-gates N3 and N4 included in integrated circuit 321. Via resistor 644 both gates N3 and N4 function as analogue inverters which are positively feedback via quartz-crystal 752 and adjustable load capacitance 542//543. The quartz-crystal which functions as absorption circuit is adjusted to exactly 10 MHz with trimmer 542. Nand-gates N1 and N2 (also included in integrated circuit 321) serve as sine-wave/square-wave pulse former and decouple the oscillator from the first decimal divider 322 and the mixer. If button CAL has not been depressed, inverter N4 is blocked via input G8 and oscillating is stopped.

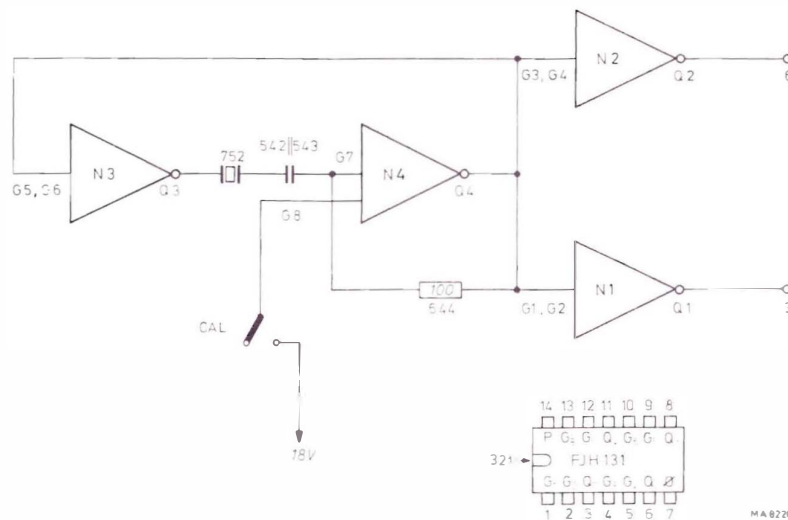

Fig. 27. Crystal oscillator

3.1.6.1.2. Decimal dividers

The first 10/1 divider is included in integrated circuit 322. If button CAL is depressed, a 1 MHz signal and its many harmonics is available at the output of this divider. This signal is supplied directly to the second 10/1 divider (323) and via RC network 649//550 to the mixer.

The second 10/1 divider supplies a 0.1 MHz signal to the mixer via RC network 650//551.

Depending on the selected frequency range the decimal dividers are blocked or not; the 10 MHz oscillator functions always if button CAL is depressed.

Frequency range	Decimal divider
.13 and .3 ... 1	322 and 323 functions
1 ... 3 and 3 ... 10	322 functions
10 ... 30 and 30 ... 80	
75 ... 110	
.45	322 and 323 functions
10.3 ... 11.1	322 and 323 functions

3.1.6.2. Mixer

The mixer consists of biased diode 409. To this diode the next signals are supplied:

- the h.f. signal, via separating transistor 312 and network 646//545, 647 and 648//547
- the 1 MHz signal
- the 0.1 MHz signal

Due to the curved characteristic of mixing diode 409 low-frequent difference signals appear as soon as the frequency of the h.f. oscillator approximates to one of the frequencies of the calibration oscillator or its harmonics.

The difference frequencies are supplied to the l.f. amplifier and limiter 324 via low-pass filter 770/552 (cut-off frequency about 25 kHz).

3.1.6.3. L.F. amplifier, limiter and indicator

The band-pass curve of l.f. amplifier 324 as a function of the h.f. signal is represented in Fig. 28.

The gain and thus the adaptation to the input signal is determined by resistor 655.

The output stage of this integrated circuit can be overloaded easily. The cut-off frequency is decreased with capacitor 557. At the collector of transistor 313 a square-wave signal is available which controls transistor 313, functioning as a switch, in such a way that capacitor 561 is discharged periodically.

The charge is complemented via indicator 815 and resistor 660. The indicator deflects if there is a difference frequency. If the difference frequency is zero or very small - if the h.f. signal equals one frequency of the calibrator or only slightly deviates - the frequency is suppressed by the l.f. amplifier and the indicator will not deflect. The same applies if the difference frequency of the mixing product is outside the band-pass curve of the l.f. amplifier. Thus the equality of h.f. and one of the calibration frequencies can be recognized by a clear minimum between two maxima.

The places where a "zero-indication" may be expected during calibration are indicated by small triangles on the corresponding scales.

If button CAL is not depressed, the input of the l.f. amplifier is blocked via diode 415 and resistor 679.

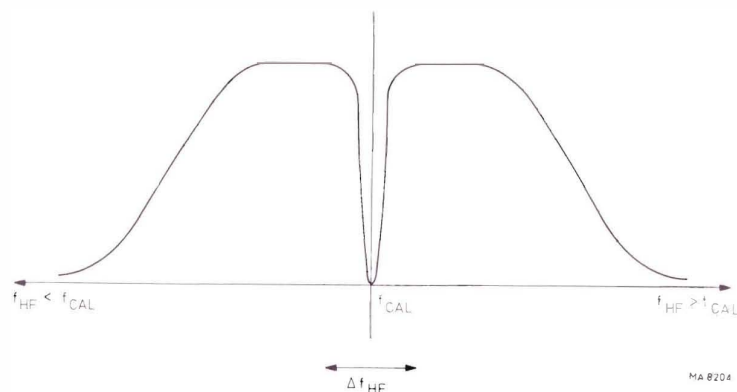

Fig. 28. Band-pass curve indicator

3.1.7. RANGE INDICATION

The six light-emitting diodes 491 ... 496 on unit 3 serve to indicate the frequency range used.

Synchronously with the range switching of the h.f. oscillator, one of the LED's is switched on via resistor 601 (on unit 3) and a combination of switches of unit 1.

3.1.8. SUPPLY

The plus potential of the -12 V and -18 V supply are connected to circuit zero. Both sources are stabilized.

The unstabilized voltages are produced by rectifier 405 on unit 2. The output voltage, divided by resistors 637/638/639, is compared with the reference voltage across zener diode 404 via operational amplifier 322.

The output voltage of operational amplifier 322 controls series transistor 311 via current amplifier 312.

The offset-voltage of the operational amplifier is reduced by resistor 641. The short-circuit current of the -12 V supply is limited by resistor 645.

The stabilizing circuit for the -18 V supply is the same as given for the -12 V supply. The reference voltage is the -12 V supply. The output voltage is compared with the reference voltage via voltage divider 635/636.

A separate secondary winding of the mains transformer supplies the voltage for the scale illumination (lamps 811 ... 813) and for the illumination of the indicator via switch 803/1A (button CAL).

3.2. Gaining access to and replacing of parts

3.2.1. CABINET PANELS

The top- and bottom plates can be taken off by sliding them backwards after first having the corresponding screws (M3) removed.

The side plates can be removed separately by removing the corresponding handle-bracket screw.

3.2.2. SCALE LAMP, ILLUMINATION OF INDICATOR

- Remove the top-plate
- Unsolder the connection wires (E, Fig. 33) of the pilot lamp
- Take out the lamp
- Slide the spare lamp until the stop
- Resolder the connection wires
- Demount the indicator according 3.2.5.
- Pull out the lamp holder and replace the lamp

3.2.3. TUNING CAPACITOR

- Remove the top- and side plates
- Set the tuning short before the right stop
- Loosen the grub screw of the drive
- Unsolder the connections of the tuning capacitor
- Loosen the 3 holding screws; pull out the tuning capacitor backwards
- Adjust the pointer according to 3.2.5.2. after mounting the drive

3.2.4. UNIT 1, PUSH-BUTTONS, UNIT 3

- Demount the tuning capacitor according to 3.2.3.
- Unsolder the connection of unit 1, loosen screws F (Fig. 33) and take out unit 1
- Demount push-button unit 802. The soldering spots, indicated in Fig. 40 must be soldered free.
- Take out and replace the push-button unit including the printed wiring board
- Unsolder the mass connection of unit 3
- Take out unit 3 sideways

Notes concerning unit 3

- The soldering temperature (260 °C) may not exceed a time of 3 seconds.
- Minimum distance from the lens is 2 mm
- Use a tong between soldering spot and diode body to conduct the heat.

3.2.5. TUNING FREQUENCY, DRIVE, SCALE AND INDICATOR

- Remove the top plate and the buttons SWEEP WIDTH and HF AMPLITUDE
- Set the drive at approximately the right stop
- + Demount the mains switch mechanically by loosening first the rear hexagonal nut and then the front ornamental ring.
Mounting up in reversed sequence
- + Demount potentiometer SWEEP WIDTH mechanically
- + Unsolder the connections of connector LF IN and 1 kHz/SWEEP OUT
- Remove the 4 screws A (Fig. 36)
- Remove the 4 screws B (Figs. 34 and 35)

- Take out the front plate together with the text plate; for this the side panels must be pushed slightly sideways
- If necessary, the indicator can be demounted; if **only** the indicator must be demounted, the actions marked with + are not necessary.

3.2.5.1. Tuning FREQUENCY; demounting

- Remove the window of the scale by removing the 5 screws C (Fig. 37).
- Now the ball-cord, return sheave, pointer and drive, which contains a slip friction clutch (D, Fig. 37) can be replaced. The indicator can then also be replaced. The drive can be pulled from the axis by loosening the grub screw; however, first remove the ball-cord.

3.2.5.2. Tuning FREQUENCY; mounting

- Bring the tuning capacitor and the slip friction clutch to the left stop; fix the grub screw previously, if necessary.
- Check the state of the ball-cord with respect to the drive, or fix a new ball-cord in such a way that the second ball is located next to the draw-spring in the lower saving of the drive (Fig. 37).
- Adjust the pointer or press the pointer-guiding on the ball-cord and adjust it so, that the pointer-line at the left-stop of the tuning capacitor and slip friction clutch is positioned over the left pair of marks of the auxiliary marks located at the left of the scales.
- Carry out the tuning - left and right stops included - several times and check the pointer adjustment again; adjust, if necessary
- Mount in reversed sequence.

3.3. Maintenance

HF Generator PM 5324 requires no maintenance because the instrument contains no components which are subject to wear.

However, to ensure reliable and faultless operation, the instrument should not be exposed to moisture, heat, corrosive vapours and excessive dust.

3.4. Survey of checking and adjusting points

	Adjusting element	Fig.	Absolute value	Measuring equipment	e.g.	Chapter	
Supply						3.5.1.	
Current consumption	—	—	$I_{r.m.s.} = 58..70 \text{ mA}$	Ammeter	PM 2411		
Supply voltages	Potentiometer 638/unit 2	41	$-12 \text{ V} \pm 20 \text{ mV}$ $-18 \text{ V} \pm 100 \text{ mV}$	Digital voltmeter	PM 2421		
Ripple	—	—	$V_{p-p} < 2 \text{ mV}$	Oscilloscope	PM 3231		
1 kHz-voltage	Potentiometer 632/unit 2	41	$V_{r.m.s.} = 2 \text{ V} \pm 20 \text{ mV}$	Digital voltmeter	PM 2421	3.5.2.	
Frequency deviation	—	—	$\pm 200 \text{ Hz}$	Counter	PM 6620		
Sawtooth voltage	Resistor 647/unit 2	41	$V_{p-p} = 10 \text{ V} \pm 0.2 \text{ V}$	Oscilloscope	PM 3231	3.5.3.	
Frequency	—	—	$25 \text{ Hz} \pm 5 \text{ Hz}$	Counter	PM 6620		
Square-wave voltage	—	—	V_{p-p} about 12.7 V	Oscilloscope	PM 3231	3.5.4.	
Duty cycle	—	—	0.4 ± 0.1	Counter	PM 6620		
HF-Amplitude	Potentiometer 612/unit 1	39	$50 \text{ mV} \pm 1 \text{ mV}$	Digital voltmeter + UHF probe + UHF T-connector	PM 2421 + PM 9203 + PM 9253	3.5.6.1.	
Amplitude response	Trimmer 538/unit 1	39	$35.4 < 50 < 70 \text{ mV}$				3.5.6.3.
Frequency	see table 1		table 1		Counter	PM 6630	3.5.6.2.
Attenuation	Potentiometer 601 in position $50 \mu\text{V}$	—	60 dB	Voltmeter		3.5.6.4.	
Amplitude modulator	Potentiometer 631/unit 1	39	$V_{r.m.s.} \leq 5 \text{ mV}$	Oscilloscope	PM 3231	3.5.5.	
Blanking of the fly-back	—	—		Oscilloscope	PM 3231	3.5.7.	
Wobble sweep a.m.- i.f. range				Measuring set up according to Fig. 31	PM 5321 PM 5120 PM 3210 874 - TPD 874 - VR	3.5.8.1.	
		see table 2					
Wobble sweep f.m. range				Measuring set up according to Fig. 30	874 - W50 (General Radio)	3.5.8.2.	
Amplitude- and frequency modulation		see table 3		Measuring instrument for frequency- and amplitude modulation or set-up according to Fig. 32	Heterodyne 2006 (Brüel & Kjaer)	3.5.9.1. 3.5.9.2. 3.5.9.3.	
Calibration frequency	Trimmer 542/unit 1	39	$10 \text{ MHz} \pm 500 \text{ Hz}$	Counter	PM 6620	3.5.10.	
Sensitivity	—		$> 50 \%$ of full scale deflection	—	—		

3.5. Checking and adjusting

3.5.1. SUPPLY

- Connect the generator to a mains voltage of 220 V
- Measure the current consumption: 58 mA_{r.m.s.} up to 70 mA_{r.m.s.}
- Measure the voltage between connections 13 and 6 of unit 2: $-12 \text{ V} \pm 20 \text{ mV}$.
If necessary, adjust with potentiometer 638 on unit 2.
- Measure the voltage between connections 12 and 6 of unit 2: $-18 \text{ V} \pm 100 \text{ mV}$
- Check the ripple voltage between connections 13-6 and 12-6 of unit 2: ripple voltage should be $< 2 \text{ mV}_{\text{p-p}}$

Survey

Connection (unit 2)	Value	Ripple	Load at separate testing	
13 - 6	$-12 \text{ V} \pm 20 \text{ mV}$	$< 2 \text{ mV}_{\text{p-p}}$	$I_L = 75 \text{ mA}$	$R_L = 160 \Omega$
12 - 6	$-18 \text{ V} \pm 100 \text{ mV}$	$< 2 \text{ mV}_{\text{p-p}}$	$I_L = 125 \text{ mA}$	$R_L = 144 \Omega$

3.5.2. 1 kHz-VOLTAGE

- Press button AM/1 kHz
- The voltage at connector 1 kHz/SWEEP OUT (or at separate testing at connection 19 of unit 2) should be $2 \text{ V}_{\text{r.m.s.}} \pm 20 \text{ mV}$
Load impedance: $\geq 100 \text{ k}\Omega$
Adjust with potentiometer 632 of unit 2, if necessary
- Check the frequency: $1 \text{ kHz} \pm 200 \text{ Hz}$
Load impedance $\geq 10 \text{ k}\Omega$

3.5.3. SAWTOOTH VOLTAGE

- Press button WOB.
- The voltage at connector 1 kHz/SWEEP OUT (or at separate testing at connection 19 of unit 2) should be $10 \text{ V}_{\text{p-p}} \pm 0.2 \text{ V}$.
Adjust with parallel resistors 647//613 on unit 2, if necessary
- Check the voltage at connection 14 of unit 2: $9 \text{ V}_{\text{p-p}}$ up to $10.15 \text{ V}_{\text{p-p}}$
Load connection 14 with $22 \text{ k}\Omega$ at separate testing (without potentiometer)
- Check the frequency at connection 14 of unit 2: $25 \text{ Hz} \pm 5 \text{ Hz}$

3.5.4. SQUARE-WAVE VOLTAGE

- Press button WOB.
- Check the voltage at connection 9 of unit 2: approximately $12.7 \text{ V}_{\text{p-p}}$
- Determine the duty cycle: 0.4 ± 0.1 (Fig. 29)

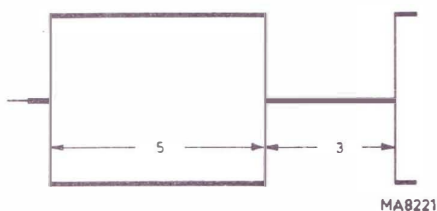

Fig. 29. Functioning of the blanking of the fly-back

3.5.5. AMPLITUDE MODULATOR, COMPENSATION OF THE MODULATION VOLTAGE

- Release all range buttons
- Press mode button AM/1 kHz; if necessary, release button WOB.
- Measure the voltage at resistor 634 of unit 1: maximum LF voltage 5 mV_{p-p}
- Adjust the compensation voltage to < 5 mV with potentiometer 631 on unit 1, if necessary.

3.5.6. HF SIGNAL

3.5.6.1. HF amplitude

- Release all buttons
- Terminate connector HF OUT with 75 Ω
- Set HF AMPLITUDE fully clockwise
- Press range button 1-3
- Measure the voltage at output HF OUT: 50 mV ± 1 mV
- Adjust the voltage to nominal with potentiometer 612 on unit 1, if necessary.

3.5.6.2. Frequency

Check the position of the scale pointer

- Set the pointer approximately to the middle of the scale
- Hold the largest knob of control FREQUENCY with one hand
- Adjust the smaller knob - against the resistance of the slipping clutch - to the right stop of the slipping clutch
- Release the large knob and set control FREQUENCY to the left stop. The pointer should now be located on both left pair of marks which are on the left alongside the scale; if not, shift the pointer on the scale cord according to 3.2.5.2. (mechanical zero point)
- Set the pointer with control FREQUENCY on the right pair of marks, which are on the left alongside the scale
- Hold the larger knob of control FREQUENCY again
- Set the small knob to the left stop of the slipping clutch (electrical zero point).

Checking the accuracy of the frequency

- Switch on the instrument 30 minutes before checking
 - Connect a counter, e.g. PM 6630 or PM 6640, to connector HF OUT
 - Turn control HF AMPLITUDE fully clockwise
 - Check the frequencies according to table 1.
- Readjust, if the tolerances are not met; use the corresponding indicated scale.

Table 1 Adjusting table h.f. oscillator

Button MHz (802/..) pressed	Pointer at mark (indicated scale)	Permissible tolerance ≤ kHz	Adjusting element	Adjusting tolerance ≤ kHz	Pointer at mark (indicated scale)	Adjusting element	Adjusting tolerance ≤ kHz
.1 - .3	1	1.5	761	0.1	3	501	0.3
.3 - 1	3	4.5	762	0.3	10	503	1
1 - 3	1	15	763	1	3	505	3
3 - 10	3	45	764	3	10	507	10
10 - 30	1	150	765	10	3	510	30
30 - 80	30	450	766	30	80	512	80
75 - 110	75	750	767	15	110	514	20
.4 - .5	.4	2	768	0.12			
10.3 - 11.1	10.3	20.6	769	5			

.1 - .3	3	4.5
.3 - 1	10	15
1 - 3	3	45
3 - 10	10	150
10 - 30	3	450
30 - 80	80	1200
75 - 110	110	1100

First check the values in the third row of table 1 in vertical sequence. If the tolerances in some ranges are not met, the begin- and end-values of these ranges have to be corrected by mutual adjustment of L and C - row 4 and 7 - so that the tolerance values of the rows 5 and 8 are obtained or even lower than these values; the adjustment of every range should end with the correction of the capacitor.

Check the compliance of the frequency response with the marking of the corresponding scale at approximately 40 % and 60 % of the range. Compare deviations with the permissible tolerances of the technical data.

3.5.6.3. HF Amplitude response

- Check the amplitude according to 3.5.6.1.
- Press range button 30-80; release all other buttons
- Set the scale pointer to mark 80
- Measure the voltage at output HF OUT: $50 \text{ mV} \pm 1 \text{ mV}$
If necessary, adjust with trimmer 538 on unit 1 to nominal value
- Tune the complete range 30 - 80 MHz. Check, that the deviation is smaller than 3 dB (minimum about 35 mV)
- Press range button 75 - 110
- Tune the complete range 75 - 110 MHz; frequency response $35.4 < 50 < 70 \text{ mV}$.

3.5.6.4. HF-attenuation

- Press range button 75 - 110
- The scale pointer may be in arbitrary position
- Terminate output HF OUT with 75Ω

- Measure the voltage at output HF OUT (e.g. with instrument 2006, Brüel & Kjaer)
- Adjust the output voltage with potentiometer HF AMPLITUDE to $50 \mu\text{V}$. Potentiometer HF AMPLITUDE should be in position $50 \mu\text{V}$

3.5.7. BLANKING THE FLY-BACK DURING WOBBLING

- Connect an oscilloscope to output HF OUT; oscilloscope settings $Y \cong 50 \text{ mV/div.}$ and $X \cong 5 \text{ msec/div.}$
Trigger the oscilloscope from connector 1 kHz/SWEEP OUT
- Turn control HF AMPLITUDE fully clockwise
- Press range button .4 - .5 and mode button WOB.
- The oscilloscope must show the picture illustrated in Fig. 29.
- Set the amplitude control of the oscilloscope to 5 mV/div. ; no HF signal should be seen on the zero line.

3.5.8. SWEEP WIDTH

3.5.8.1. Checking the AM- IF-range

- Set-up the arrangement according to Fig. 31
- Press range button .4 - .5
- Set the scale pointer to 0.46 MHz
- Release all mode buttons
- Set the frequency of the auxiliary h.f.-generator to the frequency of the instrument to be tested- slow running Lissajous figure
- Press button WOB.
- In the middle of the picture an interference mark (frequency mark) f_0 appears
- Set the frequency of the l.f.-generator, with which the auxiliary h.f.-generator is modulated (a.m.), to 20 kHz
- The side-band frequency marks B and C appear; if necessary, slightly vary the frequency of the auxiliary h.f.-generator; the distance of the frequency marks B and C correspond to twice the frequency of the l.f.-generator
- Determine the frequency sweep and the asymmetry and compare with the data given in table 2.
If necessary, correct with adjusting element 607 on unit 1.

3.5.8.2. Checking the FM range

- Set-up the arrangement according to figure 30
- Press range button 10.3 - 11.1 or 75 - 110
- Set the pointer to 10.7 MHz or 96 MHz
- Release mode buttons
- Set the frequency of the auxiliary h.f.-generator to the frequency of the instrument to be tested
- Press button WOB.
- In the middle of the picture a frequency mark f_0 (A) appears
- Set the frequency of the l.f. generator, with which the auxiliary h.f.-generator is mixed (a.m.), to $300 \text{ kHz} (\Delta f)$.
- The side-band frequency marks B and C appear; if necessary, slightly vary the frequency of the auxiliary h.f.-generator; the distance of the frequency marks B and C correspond to twice the frequency of the l.f. generator
- Determine the frequency sweep and the asymmetry and compare with the data given in table 2.
If necessary, correct with adjusting element 609 or 608 on unit 1

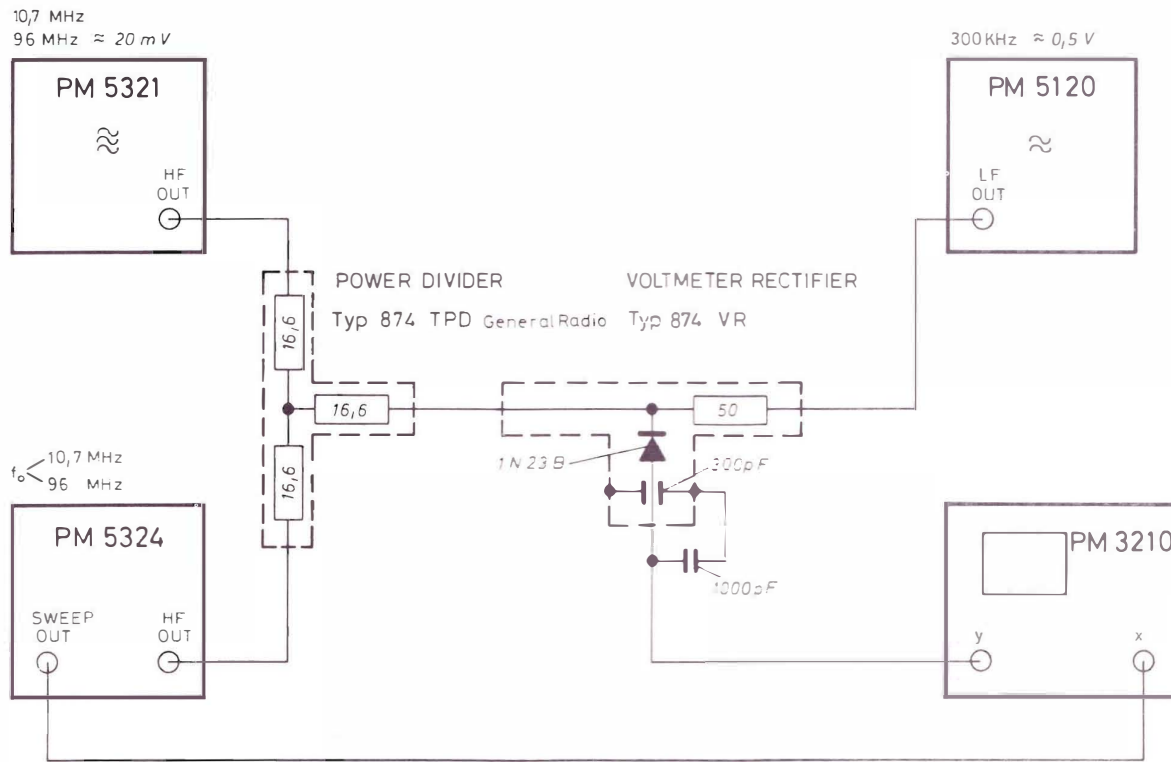

MA8222

Fig. 30. Measuring set-up to determine the frequency sweep and the symmetry

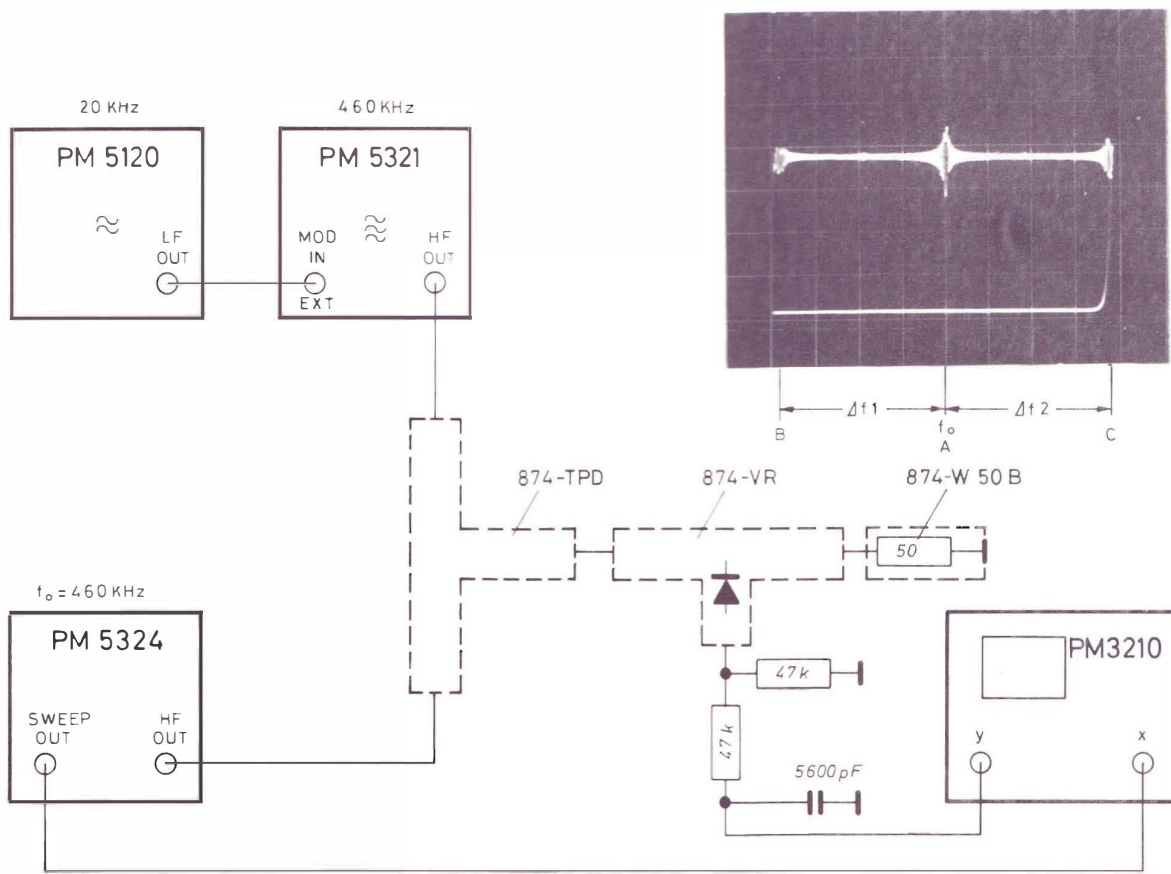

MA8223

Fig. 31. Measuring set-up to determine the frequency sweep and the symmetry

Table 2 Checking table frequency modulator

Button MHz (802/..) pressed	Scale pointer to (MHz) (indicated scale)	Frequency sweep $2 \Delta f$ kHz	Adjusting element on unit 1	Asymmetry ($\Delta f_1 - \Delta f_2$) kHz
.4 - .5	0.46	40 ± 1	607	≤ 7
	0.4	≥ 25	check	—
	0.5	≤ 58		—
10.3 - 11.1	10.7	600 ± 15	609	≤ 50
	10.3	≥ 510	check	—
	11.1	≤ 690		—
75 - 110	96	600 ± 15	608	≤ 100
	75	≥ 210	check	—
	110	≤ 1110		—

3.5.9. CHECKING THE MODULATION

Check the modulation modes according to table 3.

Table 3 Checking table for a.m. and f.m.

Press button MHz (802/..)	Scale pointer to mark	Press mode button (803/..)	Modulation depth %	Frequency sweep Δf kHz
.4 - .5	0.46	AM INT.	30 ± 5	—
		AM EXT.	> 80	—
10.3 - 11.1	10.7	AM INT.	30 ± 5	—
		AM EXT.	> 80	—
		FM INT.	—	25 ± 5
		FM EXT.	—	75 ± 15
30 - 80	96 of scale 75 - 110	AM INT.	30 ± 10	—
		AM EXT.	> 80	—
75 - 110	97	AM INT.	30 ± 10	—
		AM EXT.	> 75	—
		FM INT.	—	25 ± 5
		FM EXT.	—	75 ± 15

3.5.9.1. Checking with a modulation depth- and frequency sweep measuring instrument

- Connect the measuring instrument - e.g. type 2006 Brüel & Kjaer - to output HF OUT
- Supply a signal of 1 kHz, $2 V_{r.m.s.}$ via connector LF IN
- Determine the modulation data according to table 3 and compare the results with the limit values

If such a measuring instrument is not available check according to 3.5.9.2 and 3.5.9.3

3.5.9.2. Checking the frequency modulation according the principle of frequency marks

- Check the data of lines 5, 6, 11 and 12 of table 3 in accordance with the description given in sub-para 3.5.8.2
- External modulation voltage $2 V_{r.m.s.}$

3.5.9.3. Checking the amplitude modulation

- Check the data of lines 1 ... 4 and 7 ... 10 of table 3
- This can be effected by interpretation of a modulation trapezium or an oscillogram (Fig. 32)
- A set up for representing a modulation trapezium is given in Fig. 32.

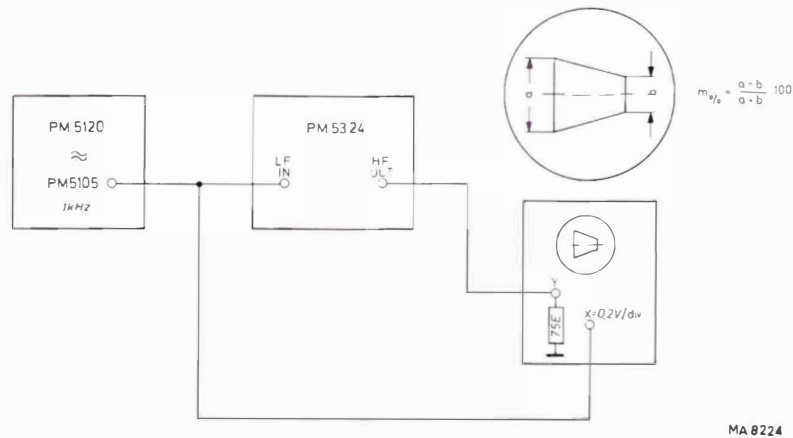

Fig. 32. Measuring set-up for representing a modulation trapezium

3.5.10. CALIBRATION

- Release all buttons
- Connect a counter, e.g. PM 6620, to test point TP of unit 1
- Press button CAL; the indicator is illuminated
- Check the frequency: 10 MHz \pm 500 Hz.
If necessary, adjust with trimmer 542 on unit 1
- Press range button .3 - 1
- Tune the range from 650 to 750 kHz slowly; near mark 7 of the indicated scale, the indicator should deflect more than half. If not, replace resistor 655 on unit 1
- Check the sensitivity in the ranges 3 - 10 and 30 - 80.

3.6. List of parts

3.6.1. MECHANICAL

<i>Item</i>	<i>Fig.</i>	<i>Qty</i>	<i>Ordering number</i>	<i>Description</i>
1	33	2	5322 460 60017	Ornamental strip
2	33	2	5322 460 60014	Ornamental surround
3	33	1	5322 414 74024	Knob, Ø 18.7
4	33	1	5322 414 74025	Knob, Ø 24
5	33	1	5322 414 74022	Knob cover
6	33	1	5322 447 94107	Security cover
7	33	2	5322 310 10044	Washer handle-bracket
8	33	2		Handle-bracket screw
9	33	2		Handle bar
10	33	2		Screw for handle bar
11	33	1	5322 276 84034	Push-button switch
12	33	3	5322 267 10004	BNC-connector 851-853
13	33	2	5322 414 74021	Knob cover
14	33	2	5322 414 74023	Knob, Ø 18.7
15	33	1	5322 455 74022	Text plate
16	33	1	5322 276 14128	Mains switch 801
17	33	1	5322 276 64009	Push-button switch 803
18	33	1	5322 450 84015	Pointer
19	33	1	5322 450 64041	Plexiglass window
20	34	4	5322 462 50101	Foot
21	34	4	5322 462 40157	Rubber stud
22	34	1	5322 492 64347	Spring
23	34	1	5322 265 30066	Mains input connector 854
24	36	1	5322 255 44064	Heat sink
25	36	1	5322 255 44065	Mica washer
26	—	1	4822 390 20023	Silicon grease
27	37	1	5322 450 34022	Scale
28	37	1	5322 528 24057	Drive
29	37	1	5322 502 14083	Grub screw
30	37	1	5322 358 54039	Ball-cord
31	37	2	5322 522 34452	Return sheave
32	—	1	5322 321 10071	Mains cable

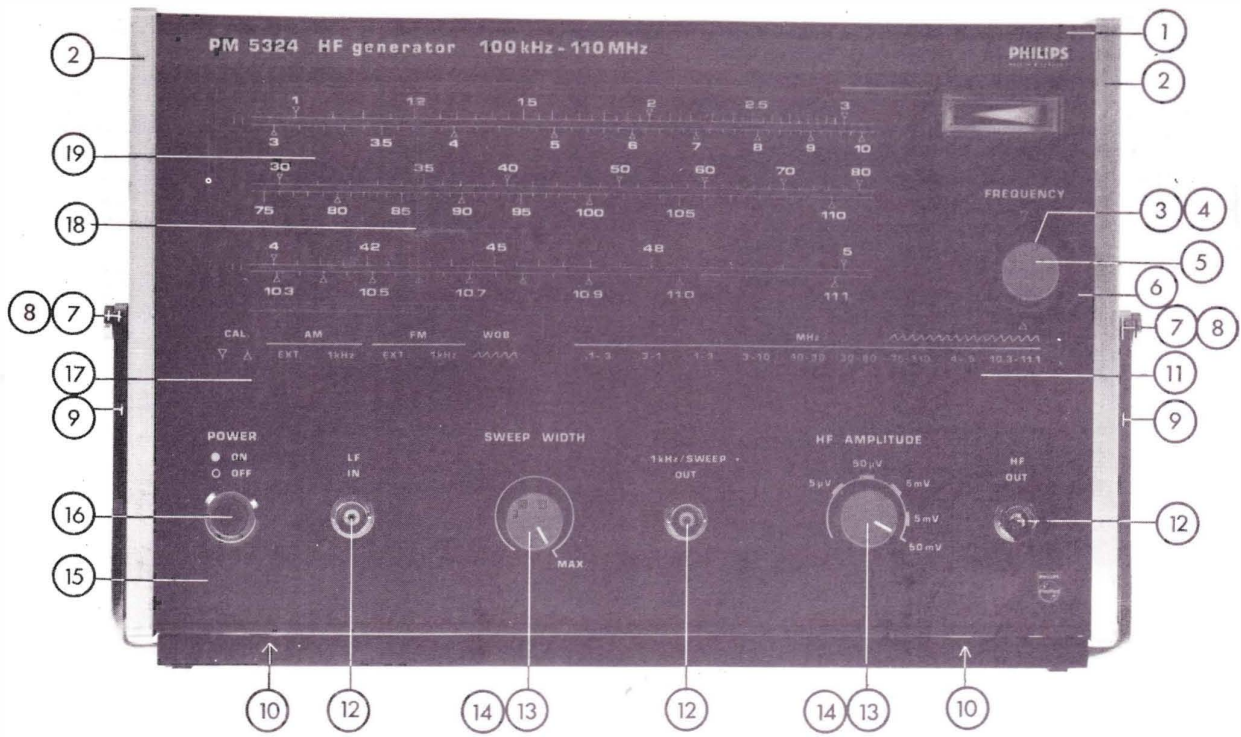

Fig. 33. Front view with item numbers

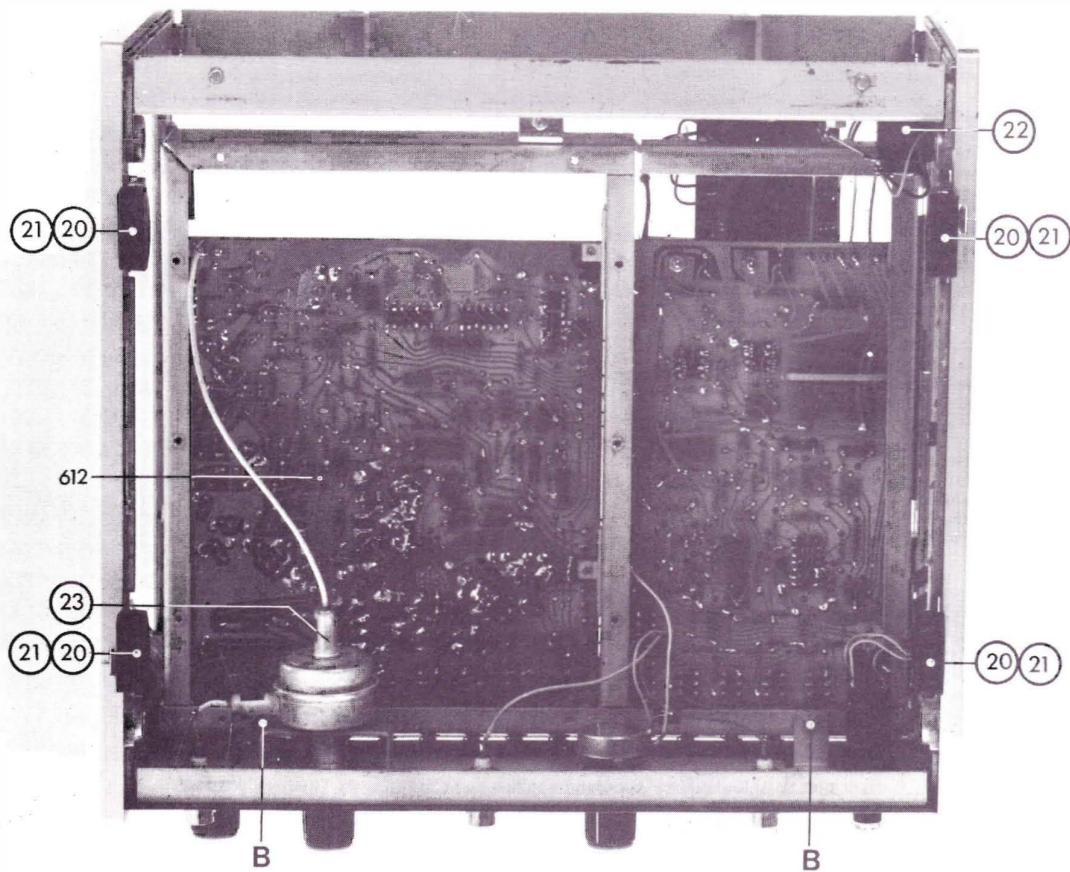

Fig. 34. Bottom view

- 1
- 2
- 3 4
- 5
- 6
- 7 8
- 11
- 9
- 12

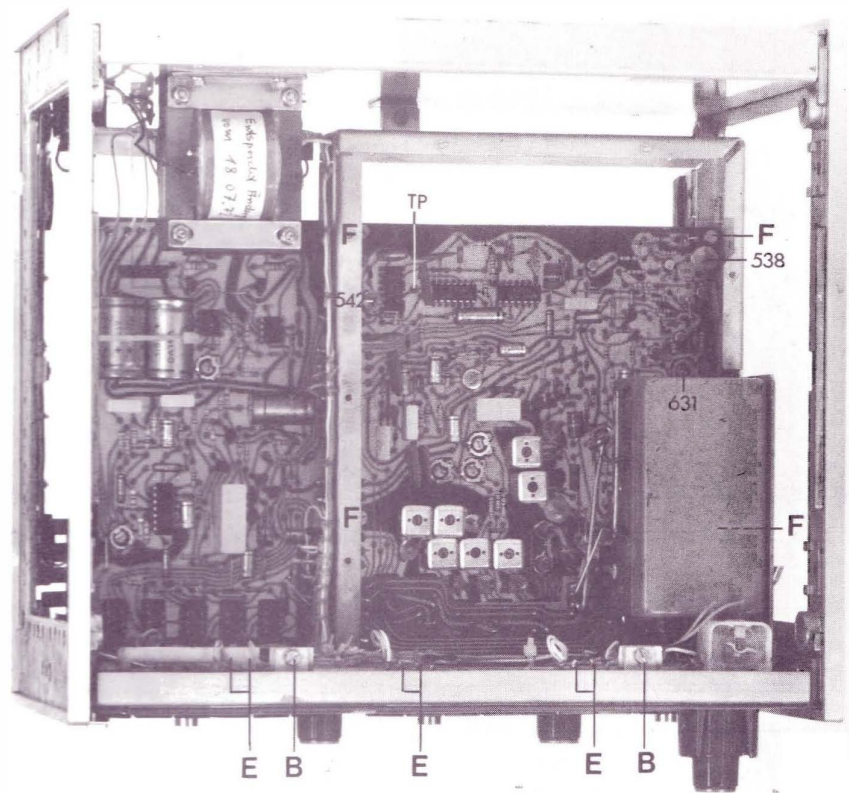

Fig. 35. Top view

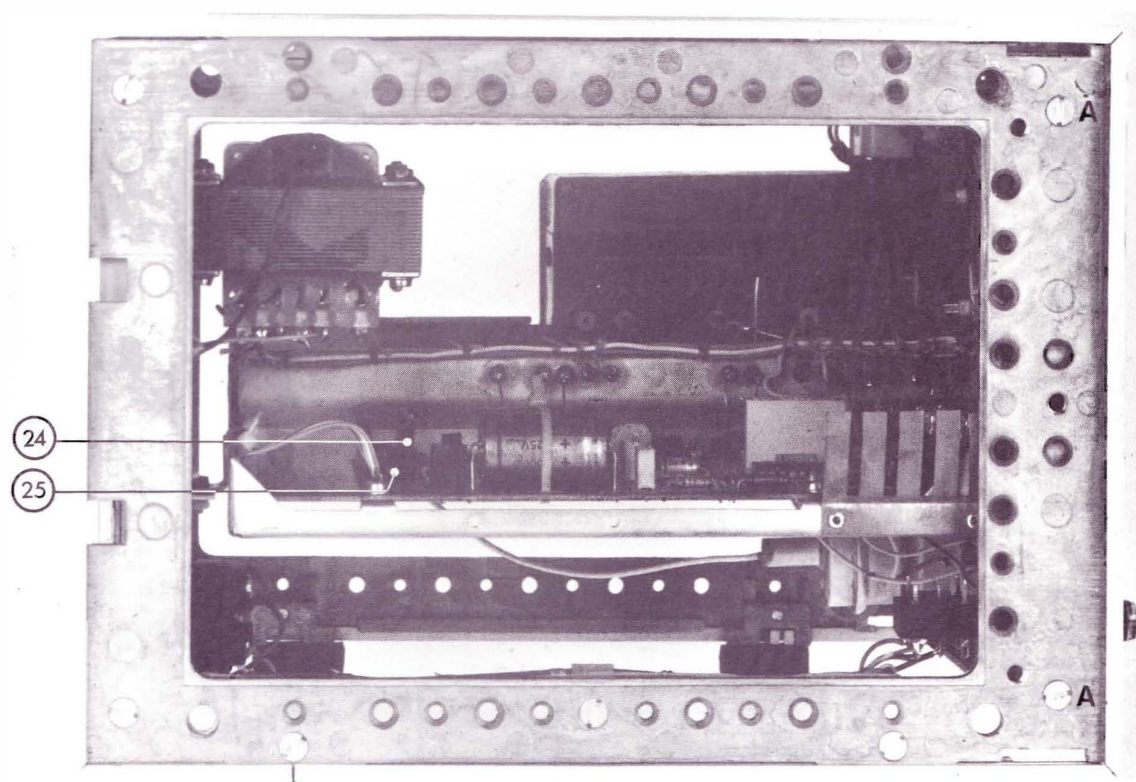

Fig. 36. Left-side view

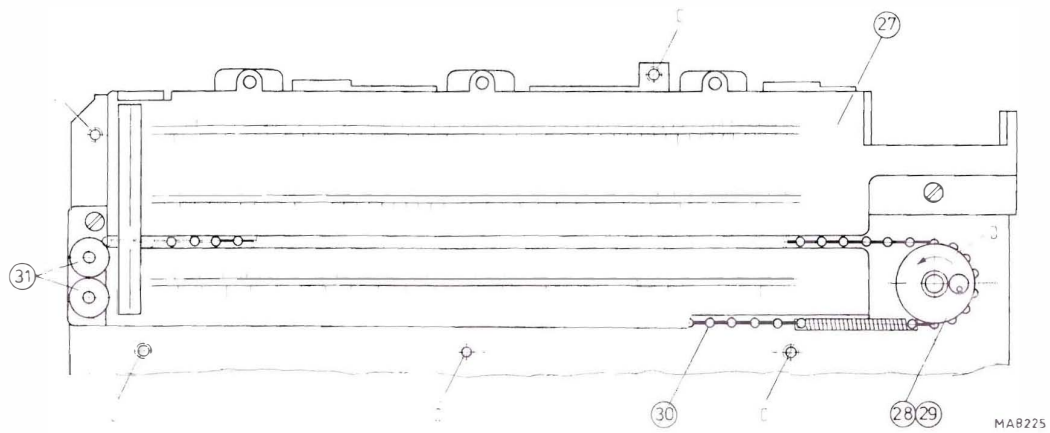

Fig. 37. Scale drive



















This parts list does not contain multi-purpose and standard parts. These components are indicated in the circuit diagram by means of identification marks. The specification can be derived from the survey below.

Diese Ersatzteilliste enthält keine Universal- und Standard-Teile. Diese sind im jeweiligen Prinzipschaltbild mit Kennzeichnungen versehen. Die Spezifikation kann aus nachstehender Übersicht abgeleitet werden.

In deze stuklijst zijn geen universele en standaardonderdelen opgenomen. Deze componenten zijn in het principeschema met een merkteken aangegeven. De specificatie van deze merktekens is hieronder vermeld.

La présente liste ne contient pas des pièces universelles et standard. Celles-ci ont été repérées dans le schéma de principe. Leurs spécifications sont indiquées ci-dessous.

Esta lista de componentes no comprende componentes universales ni standard. Estos componentes están provistos en el esquema de principio de una marca. El significado de estas marcas se indica a continuación.

	Carbon resistor E24 series Kohleschichtwiderstand, Reihe E24 Koolweerstand E24 reeks Résistance au carbone, série E24 Resistencia de carbón, serie E24	} 0,125 W	5%		Carbon resistor E12 series Kohleschichtwiderstand, Reihe E12 Koolweerstand E12 reeks Résistance au carbone, série E12 Resistencia de carbón, serie E12	} 1 W \leq 2,2 M Ω , 5% > 2,2 M Ω , 10%
	Carbon resistor E12 series Kohleschichtwiderstand, Reihe E12 Koolweerstand E12 reeks Résistance au carbone, série E12 Resistencia de carbón, serie E12			} 0,25 W \leq 1 M Ω , 5% > 1 M Ω , 10%		
	Carbon resistor E24 series Kohleschichtwiderstand, Reihe E24 Koolweerstand E24 reeks Résistance au carbone, série E24 Resistencia de carbón, serie E24	} 0,5 W \leq 5 M Ω , 1% > 5 \leq 10 M Ω , 2% > 10 M Ω , 5%			Wire-wound resistor Drahtwiderstand Draadgewonden weerstand Résistance bobinée Resistencia bobinada	} 0,4 - 1,8 W
	Carbon resistor E12 series Kohleschichtwiderstand, Reihe E12 Koolweerstand E12 reeks Résistance au carbone, série E12 Resistencia de carbón, serie E12		} 0,5 W \leq 1,5M Ω , 5% > 1,5M Ω , 10%		Wire-wound resistor Drahtwiderstand Draadgewonden weerstand Résistance bobinée Resistencia bobinada	
	Wire-wound resistor Drahtwiderstand Draadgewonden weerstand Résistance bobinée Resistencia bobinada	} 10 W		5%		Tubular ceramic capacitor Rohrkondensator Keramische kondensator, buistype Condensateur céramique tubulaire Condensador cerámico tubular
	Tubular ceramic capacitor Rohrkondensator Keramische kondensator, buistype Condensateur céramique tubulaire Condensador cerámico tubular		} 700 V			Polyester capacitor Polyesterkondensator Polyesterkondensator Condensateur au polyester Condensador polyester
	Ceramic capacitor, "pin-up" Keramikkondensator "Pin-up" (Perltyp) Keramische kondensator "Pin-up" type Condensateur céramique, type perle Condensador cerámico, versión "colgable"	} 500 V			Flat-foil polyester capacitor Miniatuur-Polyesterkondensator (flacn) Platte miniatuur polyesterkondensator Condensateur au polyester, type plat Condensador polyester, tipo de placas planas	} 250 V
	"Microplate" ceramic capacitor Miniatuur-Scheibenkondensator "Microplate" keramische kondensator Condensateur céramique "microplata" Condensador cerámico "microplaca"		} 30 V		Paper capacitor Papierkondensator Papierkondensator Condensateur au papier Condensador de papel	
	Mica capacitor Glimmerkondensator Micakondensator Condensateur au mica Condensador de mica	} 500 V			Wire-wound trimmer Drahttrimmer Draadgewonden trimmer Trimmer à fil Trimmer bobinado	} 500 V
	Tubular ceramic trimmer Rohrtrimmer Buisvormige keramische trimmer Trimmer céramique tubulaire Trimmer cerámico tubular					



For multi-purpose and standard parts, please see PHILIPS' Service Catalogue.

Für die Universal- und Standard-Teile siehe den PHILIPS Service-Katalog.

Voor universele en standaardonderdelen raadplege men de PHILIPS Service Catalogus.

Pour les pièces universelles et standard veuillez consulter le Catalogue Service PHILIPS.

Para piezas universales y standard consulte el Catálogo de Servicio PHILIPS.

Resistors

<i>Item</i>	<i>Ordering number</i>	<i>Value (Ω)</i>	<i>%</i>	<i>Type</i>	<i>Description</i>
601	5322 105 40007	75	25	0.1 W	HF-voltage divider
602	5322 101 24012	22 k			Potentiometer
Unit 1					
606	5322 116 50253	324 k	1	MR30	Metal film
607	5322 100 10088	220 k	20	0.1 W	Potentiometer
608	4822 100 10107	470 k	20	0.1 W	Potentiometer
609	5322 100 10088	220 k	20	0.1 W	Potentiometer
610	5322 116 54328	51 k	2	CR25	Carbon
612	5322 100 10036	4.7 k	20	0.1 W	Potentiometer
616	5322 116 54328	51 k	2	CR25	Carbon
623	5322 116 54202	7.5 k	2	CR25	Carbon
626	5322 116 50095	510 k	2	CR25	Carbon
628	5322 116 54207	1 k	2	CR25	Carbon
630	5322 116 50752	1.5 k	2	CR25	Carbon
631	5322 100 10036	4.7 k	20	0.1 W	Potentiometer
663	5322 116 54188	1 M	1	MR30	Metal film
665	5322 116 54327	10 k	1	MR25	Metal film
666	5322 116 50726	36.5 k	1	MR25	Metal film
667	5322 116 50897	18.2 k	1	MR25	Metal film
668	5322 116 50666	73.2 k	1	MR25	Metal film
669	5322 116 50446	66.5 k	1	MR25	Metal film
Unit 2					
601	5322 116 50524	3 k	2	CR25	Carbon
602	5322 116 54148	9.1 k	2	CR25	Carbon
603	5322 116 50859	91 k	2	CR25	Carbon
604	5322 116 54293	4.7 k	2	CR25	Carbon
605	5322 116 54147	3.9 k	2	CR25	Carbon
606	5322 116 54079	36 k	2	CR25	Carbon
607	5322 116 50872	62 k	2	CR25	Carbon
611	5322 116 50747	1 k	2	CR25	Carbon
612	5322 116 50603	360 k	2	CR25	Carbon
614	5322 116 54405	750 k	2	CR25	Carbon
615	5322 116 54343	5.1 k	2	CR25	Carbon
616	5322 116 50747	1 k	2	CR25	Carbon
617	5322 116 50603	360 k	2	CR25	Carbon
621	5322 116 50309	24 k	2	CR25	Carbon
623	5322 116 54191	30 k	2	CR25	Carbon
624	5322 116 54171	2.2 k	2	CR25	Carbon
625	5322 116 54089	6.2 k	2	CR25	Carbon
629	5322 116 54343	5.1 k	2	CR25	Carbon
632	4822 100 10035	10 k	20	0.1 W	Potentiometer
635	5322 116 54001	15 k	1	MR25	Metal film
636	5322 116 54202	7.5 k	1	MR25	Metal film
638	4822 100 10029	2.2 k	20	0.1 W	Potentiometer

Capacitors

<i>Item</i>	<i>Ordering number</i>	<i>Value</i>	<i>%</i>	<i>V</i>	<i>Description</i>
581	5322 122 70069	100 pF	10	350	Lead feed-through
582	5322 122 70069	100 pF	10	350	Lead feed-through
583	4822 122 70063	2.2 nF	-20/+50	400	Feed-through
584	4822 122 70063	2.2 nF	-20/+50	400	Feed-through
585	4822 122 70063	2.2 nF	-20/+50	400	Feed-through
586	4822 122 70063	2.2 nF	-20/+50	400	Feed-through
587	4822 122 70063	2.2 nF	-20/+50	400	Feed-through
588	4822 122 70063	2.2 nF	-20/+50	400	Feed-through
589	4822 122 70063	2.2 nF	-20/+50	400	Feed-through
590	4822 122 70063	2.2 nF	-20/+50	400	Feed-through
591	4822 122 70063	2.2 nF	-20/+50	400	Feed-through
592	4822 122 70063	2.2 nF	-20/+50	400	Feed-through
593	4822 122 70063	2.2 nF	-20/+50	400	Feed-through
594	4822 122 70063	2.2 nF	-20/+50	400	Feed-through
595	4822 122 70063	2.2 nF	-20/+50	400	Feed-through
Unit 1					
596	5322 125 14009				Tuning
501	4822 125 50045	2...22 pF		100	Trimmer
503	4822 125 50045	2...22 pF		100	Trimmer
505	4822 125 50045	2...22 pF		100	Trimmer
507	4822 125 50045	2...22 pF		100	Trimmer
508	4822 122 31072	4.7 pF	±0.25 p	100	Ceramic
509	4822 122 31177	470 pF	2	100	Ceramic
510	4822 125 50045	2...22 pF		100	Trimmer
511	4822 122 31061	18 pF	2	100	Ceramic
512	4822 125 50045	2...22 pF		100	Trimmer
514	4822 125 50045	2...22 pF		100	Trimmer
515	4822 122 31061	18 pF	2	100	Ceramic
516	4822 125 50045	2...22 pF		100	Trimmer
518	4822 125 50017	5.5...65 pF		100	Trimmer
519	4822 122 31081	100 pF	2	100	Ceramic
520	4822 122 31056	12 pF	2	100	Ceramic
521	4822 122 31177	470 pF	2	100	Ceramic
522	4822 122 31165	300 pF	2	100	Ceramic
523	5322 122 10107	100 nF	-20/+80	30	Ceramic
524	5322 121 40197	1 μF	20	100	Polyester
525	5322 122 30103	22 nF	-20/+100	40	Ceramic
526	5322 122 30103	22 nF	-20/+100	40	Ceramic
527	4822 122 31211	100 pF	5	400	Ceramic
528	5322 122 10107	100 nF	-20/+80	30	Ceramic
529	5322 122 30103	22 nF	-20/+100	40	Ceramic
530	4822 124 20461	47 μF		10	Electrolytic
531	5322 122 30103	22 nF	-20/+100	40	Ceramic
532	5322 122 30103	22 nF	-20/+100	40	Ceramic
533	5322 122 30103	22 nF	-20/+100	40	Ceramic
534	4822 124 20475	10 μF		25	Electrolytic
535	5322 122 30109	1.5 pF	0.25 p	100	Ceramic
536	5322 122 30103	22 nF	-20/+100	40	Ceramic
537	5322 122 10107	100 nF	-20/+80	30	Ceramic
538	4822 125 50017	5.5...65 pF		100	Trimmer
539	4822 122 31177	470 pF	2	100	Ceramic

<i>Item</i>	<i>Ordering number</i>	<i>Value</i>	<i>%</i>	<i>V</i>	<i>Description</i>
540	5322 122 10107	100 nF	-20/+80	30	Ceramic
541	5322 122 30103	22 nF	-20/+100	40	Ceramic
542	4822 125 50045	2...22 pF		100	Trimmer
543	4822 122 31063	22 pF	2	100	Ceramic
544	4822 122 31175	1 nF	10	100	Ceramic
545	4822 122 31081	100 pF	2	63	Ceramic
546	5322 122 10107	100 nF	-20/+80	30	Ceramic
547	4822 122 31207	68 pF	10	400	Ceramic
548	4822 122 31207	68 pF	10	400	Ceramic
549	5322 122 10107	100 nF	-20/+80	30	Ceramic
550	4822 122 31207	68 pF	10	400	Ceramic
551	4822 122 31165	300 pF	2	100	Ceramic
552	5322 121 40323	100 nF	10	100	Polyester
553	5322 124 24063	1 μ F		63	Electrolytic
554	5322 122 10107	100 nF	-20/+80	30	Ceramic
555	4822 124 20476	22 μ F		25	Electrolytic
556	4822 124 20461	47 μ F		10	Electrolytic
557	5322 122 30103	22 nF	-20/+100	40	Ceramic
558	4822 124 20476	22 μ F		25	Ceramic
559	4822 121 40045	22 nF	10	250	Polyester
560	5322 122 10107	100 nF	-20/+80	30	Ceramic
561	4822 121 40232	220 nF	20	100	Polyester
562	5322 122 10107	100 nF	-20/+80	30	Ceramic
563	4822 122 31211	100 pF	5	400	Ceramic
564	5322 122 30103	22 nF	-20/+100	40	Ceramic
565	4822 124 20461	47 μ F		10	Electrolytic
566	4822 122 31072	47 pF	2	100	Ceramic
567	4822 124 20463	100 μ F		10	Electrolytic
568	5322 122 30103	22 nF	-20/+100	40	Ceramic
Unit 2					
501	5322 121 40283	3.3 μ F	10	100	Polyester
502	4822 124 20461	47 μ F		10	Electrolytic
503	4822 124 20514	1000 μ F		6.3	Electrolytic
504	4822 124 20461	47 μ F		10	Electrolytic
505	5322 124 24063	1 μ F		63	Electrolytic
506	5322 121 40323	100 nF	10	100	Polyester
507	5322 121 40323	100 nF	10	100	Polyester
508	5322 124 24063	1 μ F		63	Electrolytic
509	4822 124 20461	47 μ F		10	Electrolytic
510	5322 124 24063	1 μ F		63	Electrolytic
511	4822 124 20529	1000 μ F		25	Electrolytic
512	4822 124 20529	1000 μ F		25	Electrolytic
513	4822 121 50414	3 nF	5	63	Polyester
514	4822 124 20476	22 μ F		25	Electrolytic
515	4822 122 31175	1 nF	10	100	Ceramic
516	4822 122 31175	1 nF	10	100	Ceramic

Miscellaneous

<i>Item</i>	<i>Ordering number</i>	<i>Description</i>
391	5322 216 64112	Unit 1; printed wiring board
392	5322 216 64113	Unit 2; printed wiring board
393	5322 216 64114	Unit 3; printed wiring board
751	5322 146 24059	Mains transformer
752	5322 242 74036	Quartz crystal 10 MHz
761	5322 156 14019	L1, Coil 3.56 mH
762	5322 156 14021	L2, Coil 366 μ H
763	5322 156 14022	L3, Coil 35.6 μ H
764	5322 156 14023	L4, Coil 3.66 μ H
765	5322 156 14024	L5, Coil 0.3 μ H
766	5322 157 44001	L6, Coil
767	5322 157 44002	L7, Coil
768	5322 156 14025	L8, Coil 1.58 mH
769	5322 156 14026	L9, Coil 0.94 μ H
770	5322 158 14044	Coil 1.5 mH
771	5322 158 10278	Coil 1 mH
772	5322 158 14065	Coil 47 mH
811	5322 134 44072	Lamp, 40 mA
812	5322 134 44072	Lamp, 40 mA
813	5322 134 44072	Lamp, 40 mA
815	5322 344 64041	Indicator 120 μ A, Ri = 1500 Ω

Semi-conductors**Diodes**

<i>Type</i>	<i>Ordering number</i>	<i>Qty</i>	<i>Location</i>
BB106	5322 130 30769	5	Unit 1: 401, 402, 403, 411, 412
BAX13	5322 130 40182	6	Unit 1: 404, 405, 406, 407, 408, 410
AA119	5322 130 40229	1	Unit 1: 409
BA217	4822 130 30703	4	Unit 1: 413, 414, 415 Unit 2: 402
BA216	5322 130 30702	1	Unit 2: 401
BZX79-C5V1	5322 130 30767	1	Unit 2: 404
BY164	5322 130 30414	1	Unit 2: 405
MV50	5322 130 34259	6	Unit 3: 491, 492, 493, 494, 495, 496

Transistors

<i>Type</i>	<i>Ordering number</i>	<i>Qty</i>	<i>Location</i>
BD135	5322 130 40645	1	311
BD136	5322 130 40712	1	314
BFX89	5322 130 40542	8	Unit 1: 301, 302, 304, 308, 309, 310, 311, 312
BFW10	5322 130 40443	1	Unit 1: 303
BF254	5322 130 44117	2	Unit 1: 305, 306
BC238C	5322 130 44198	5	Unit 1: 307, 314, 315 Unit 2: 304, 306
BC238	5322 130 40758	4	Unit 1: 313 Unit 2: 305, 307, 312
BC308	5322 130 44119	3	Unit 2: 301, 302, 313

Integrated circuits

<i>Type</i>	<i>Ordering number</i>	<i>Qty</i>	<i>Location</i>
FJH131/7400	5322 209 84143	1	Unit 1: 321
SN7490N	5322 209 84114	2	Unit 1: 322, 323
TAA310A	5322 209 84361	1	Unit 1: 324
CA3086	5322 209 84111	1	Unit 2: 321
SN72741P	5322 209 84163	2	Unit 2: 322, 323

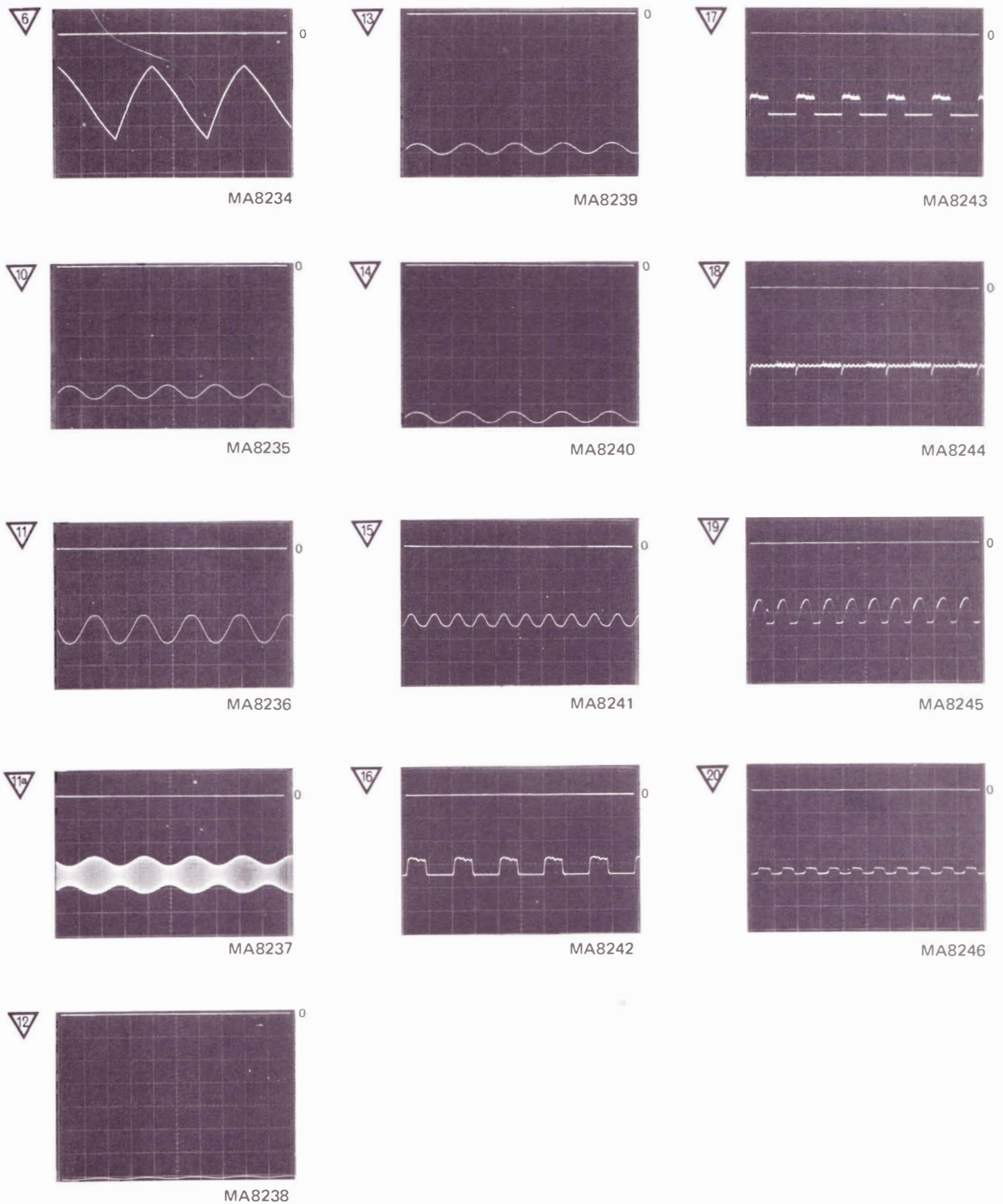

Remarks

- Oscillograms recorded with Tektronix oscilloscope, type 561A + plug in 3A6
- For settings of oscilloscope and PM 5324 see table 4, page 55

Fig. 38. Oscillograms of unit 1

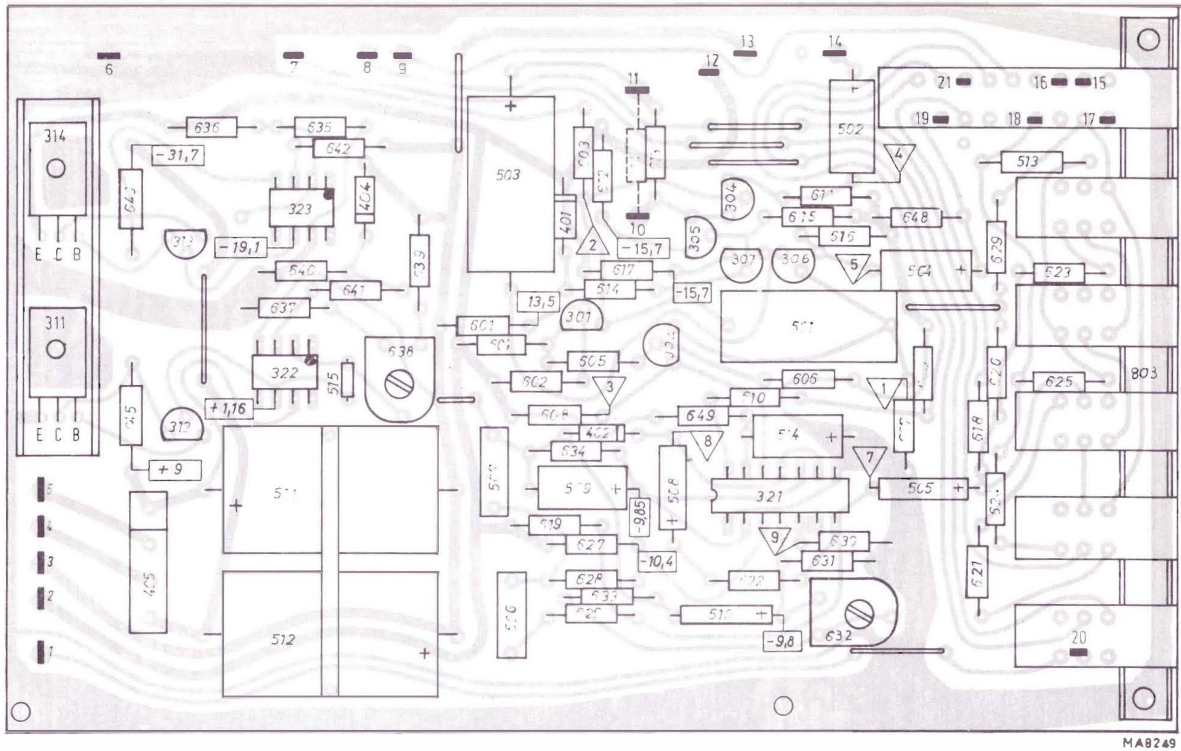
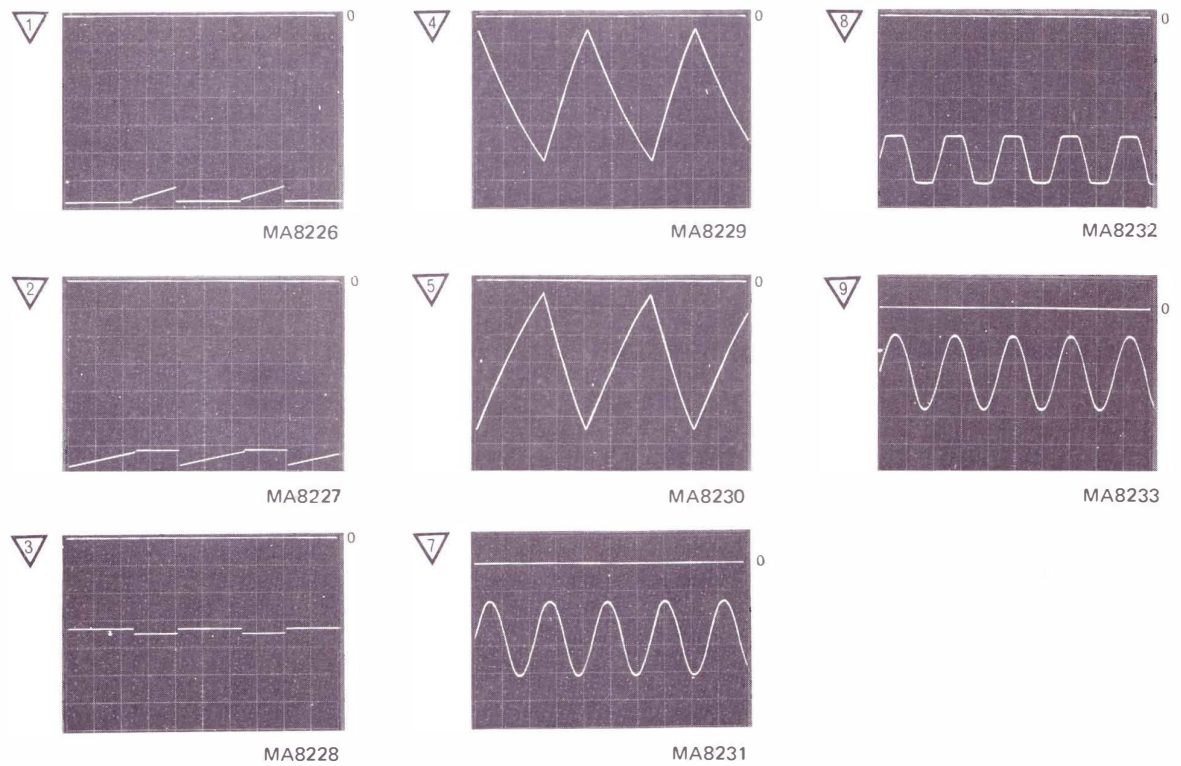

Fig. 41. Printed wiring board 2



Remarks

- Oscillograms recorded with Tektronix oscilloscope, type 501A + plug in 3A6
- For settings of oscilloscope and PM 5324 see table 4, page 55

Fig. 42. Oscillograms of unit 2

Table 4 Settings of oscilloscope and PM 5324

Oscillogram number	Oscilloscope		PM 5324	
	Y V/cm	X .. secs./cm	Pressed button	Other adjustments
1	2	10 m	WOB. .4 - .5	SWEEP WIDTH to max. FREQUENCY at 470 kHz
2	2	10 m	WOB. .4 - .5	
3	5	10 m	WOB. .4 - .5	
4	2	10 m	WOB. .4 - .5	
5	2	10 m	WOB. .4 - .5	
6	2	10 m	WOB. .4 - .5	
7	2	0.5 m	.4 - .5	FREQUENCY at 470 kHz No modulation
8	2	0.5 m	.4 - .5	
9	2	0.5 m	.4 - .5	
10	2	1 μ	.4 - .5	FREQUENCY at 470 kHz No modulation HF AMPLITUDE 50 mV Output terminated with 75 Ω
11	0.1	1 μ	.4 - .5	
11a	0.1	0.5 m	.4 - .5 AM 1 kHz	FREQUENCY at 470 kHz HF AMPLITUDE 50 mV Output terminated with 75 Ω
12	2	1 μ	.4 - .5	
13	1	1 μ	.4 - .5	FREQUENCY at 470 kHz No modulation HF AMPLITUDE 50 mV Output terminated with 75 Ω
14	1	1 μ	.4 - .5	
15	5	0.1 μ	.4 - .5	FREQUENCY at 470 kHz No modulation HF AMPLITUDE 50 mV Output terminated with 75 Ω
16	5	0.5 μ	CAL. .4 - .5	
17	5	5 μ	CAL. .4 - .5	
18	5	5 μ	CAL. .4 - .5	
19	5	0.5 m	.4 - .5	FREQUENCY at 402 kHz No modulation HF AMPLITUDE 50 mV Output terminated with 75 Ω
20	5	0.5 m	.4 - .5	

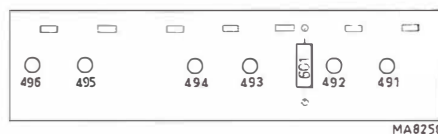

Fig. 43. Printed wiring board 3

QUALITY REPORTING

CODING SYSTEM FOR FAILURE DESCRIPTION

The following information is meant for Philips service workshops only and serves as a guide for exact reporting of service repairs and maintenance routines on the workshop charts.

For full details reference is made to Information G1 (Introduction) and Information Cd 689 (Specific information for Test and Measuring Instruments).

LOCATION

□□□□

Unit number

e.g. 000A or 0001 (for unit A or 1; not 00UA or 00U1)

or: Type number of an accessory (only if delivered with the equipment)

e.g. 9051 or 9532 (for PM 9051 or PM 9532)

or: Unknown/Not applicable
0000

CATEGORY

□

- 0 Unknown, not applicable (fault not present, intermittent or disappeared)
- 1 Software error
- 2 Readjustment
- 3 Electrical repair (wiring, solder joint, etc.)
- 4 Mechanical repair (polishing, filing, remachining, etc.)
- 5 Replacement
- 6 Cleaning and/or lubrication
- 7 Operator error
- 8 Missing items (on pre-sale test)
- 9 Environmental requirements are not met

COMPONENT/SEQUENCE NUMBER

□□□□□

Enter the identification as used in the circuit diagram, e.g.:

GR1003	Diode GR1003
TS0023	Transistor TS23
IC0101	Integrated circuit IC101
RO...	Resistor, potentiometer
CO...	Capacitor, variable capacitor
BO...	Tube, valve
LA...	Lamp
VL...	Fuse
SK...	Switch
BU...	Connector, socket, terminal
TO...	Transformer
LO...	Coil
XO...	Crystal
CB...	Circuit block
RE...	Relay
ME...	Meter, indicator
BA...	Battery
TR...	Chopper

Parts not identified in the circuit diagram:

990000	Unknown/Not applicable
990001	Cabinet or rack (text plate, emblem, grip, rail, graticule, etc.)
990002	Knob (incl. dial knob, cap, etc.)
990003	Probe (only if attached to instrument)
990004	Leads and associated plugs
990005	Holder (valve, transistor, fuse, board, etc.)
990006	Complete unit (p.w. board, h.t. unit, etc.)
990007	Accessory (only those without type number)
990008	Documentation (manual, supplement, etc.)
990009	Foreign object
990099	Miscellaneous

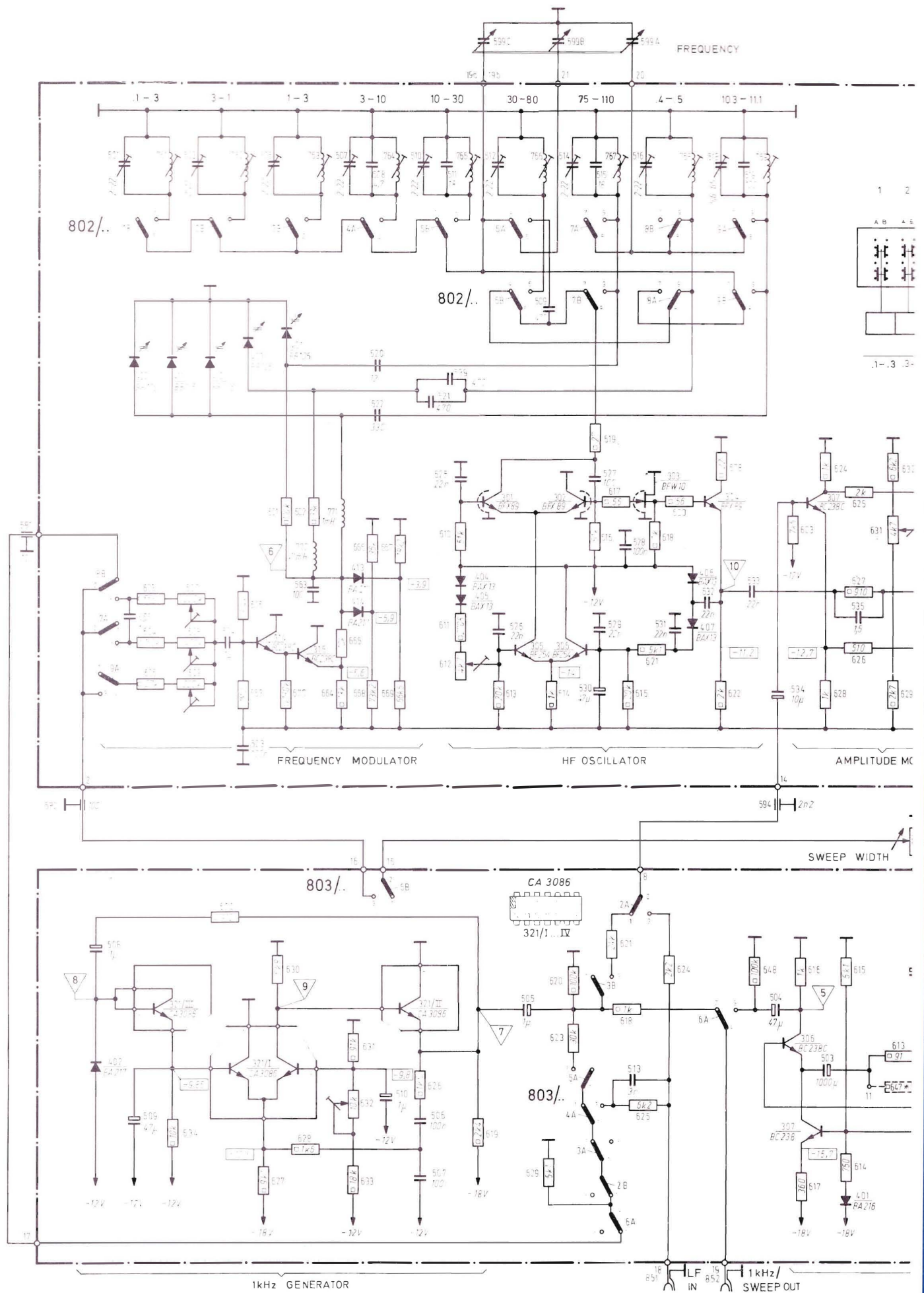

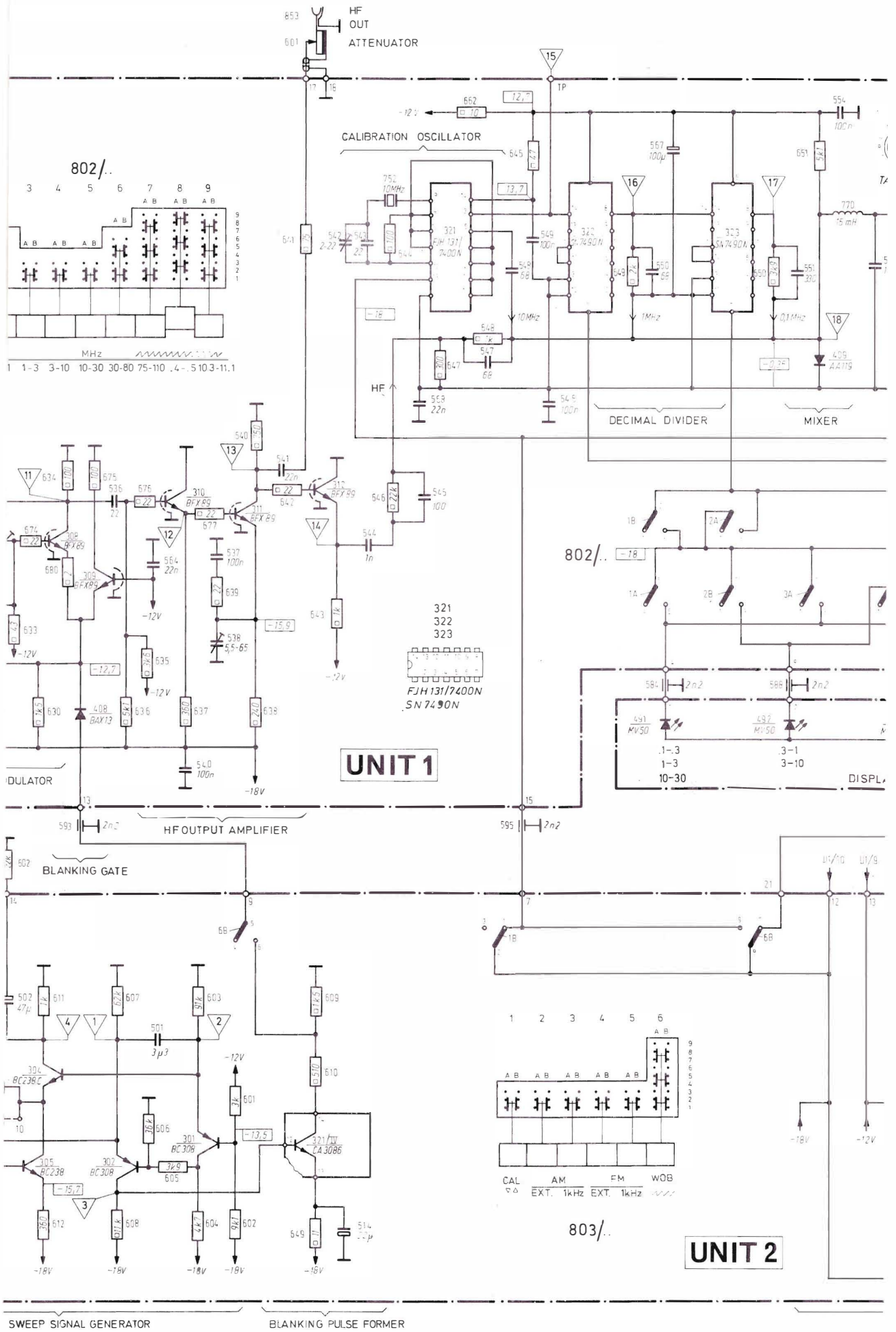

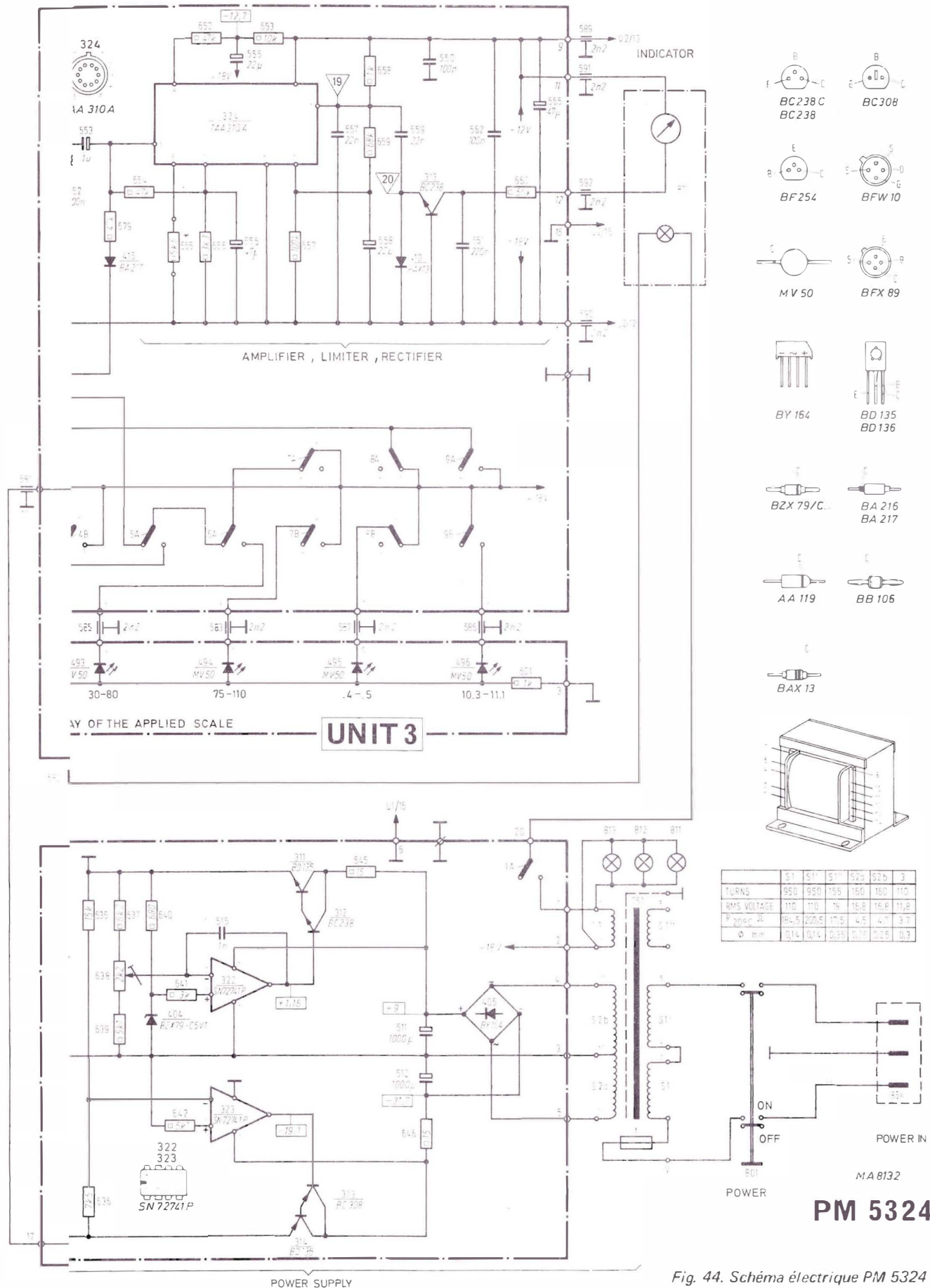

Fig. 44. Schéma électrique PM 5324

Argentina: Philips Argentina S.A., Casilla Correo 3479, Buenos Aires; tel. T.E. 70, 7741 al 7749

Australia: Philips Electrical Pty Ltd., Philips House, 69-79 Clarence Street, Box 2703 G.P.O., Sydney; tel. 2.0223

België/Belgique: M.B.L.E., Philips Bedrijfs-apparatuur, 80 Rue des Deux Gares, Bruxelles; tel. 230000

Bolivia: Philips Sudamericana, Casilla 1609, La Paz; tel. 5270-5664

Brasil: S.A. Philips Do Brasil, Inbelsa Division; Avenida Paulista 2163; P.O. Box 8681, Sao Paulo S.P.; tel. 81-2161

Burundi: Philips S.A.R.L., Avenue de Grâce, B.P. 900, Bujumbura

Canada: Philips Electronic Industries Ltd., Electronic Equipment Division, Philips House, 116 Vanderhoof Avenue, Toronto 17 (Ontario); tel. 425-5161

Chile: Philips Chilena S.A., Casilla 2687, Santiago de Chile; tel. 35081

Colombia: Industrias Philips de Colombia S.A., Calle 13 no. 51-03, Apartado Nacional 1505, Bogota; tel. 473640

Costa Rica: Philips de Costa Rica Ltd., Apartado Postal 4325, San José; tel. 210111

Danmark: Philips Elektronik Systemer A/S Afd. Industri & Forskning; Strandlodsvej 4 2300-København S; Tel (0127) AS 2222; telex 27045

Deutschland (Bundesrepublik): Philips Elektronik Industrie GmbH, Röntgenstrasse 22, Postfach 630111, 2 Hamburg 63; tel. 501031

Ecuador: Philips Ecuador S.A., Casilla 343, Quito; tel. 239080

Eire: Philips Electrical (Ireland) Ltd., Newstead, Clonskeagh, Dublin 14; tel. 976611

El Salvador: Philips de El Salvador, Apartado Postal 865, San Salvador; tel. 217441

España: Philips Ibérica S.A.E., Avenida de America, Apartado 2065, Madrid 17; tel. 2462200

Ethiopia: Philips Ethiopia (Priv. Ltd. Co.), P.O.B. 2565; Cunningham Street, Addis Abeba; tel. 48300

France: Philips Industrie, Division de la S.A. Philips Industrielle et Commerciale 105, Rue de Paris, 93 002 Bobigny; tel. 84527-09

Ghana: Philips (Ghana) Ltd., P.O.B. M 14, Accra; tel. 66019

Great Britain: Pye Unicam Ltd., York Street, Cambridge; tel. (0223) 58866

Guatemala: Compañia Comercial Philips de

Guatemala S.A., Apartado Postal 238, Guatemala City; tel. 64857

Hellas: Philips S.A. Hellénique, B.P. 153, Athens; tel. 230476

Hong Kong: Philips Hong Kong Ltd., P.O.B. 2108, St. George's Building, 21st floor, Hong Kong; tel. H-249246

India: Philips India Ltd., Shivsagar Estate, Block "A", Dr. Annie Besant Road, P.O.B. 6598, Worli, Bombay 18; tel. 370071

Indonesia: P. T. Philips Development Corporation, Djalan Proklamasi 33, P.O.B. 2287, Djakarta; tel. 51985-51986

Iran: Philips Iran Ltd., P.O.B. 1297, Teheran; tel. 48344-68344

Island: Heimilistaeki SF, Saetún 8, Reykjavik; tel. 24000

Islas Canarias: Philips Ibérica S.A.E., Triana 132, Las Palmas; Casilla 39-41, Santa Cruz de Tenerife

Italia: Philips S.p.A., Sezione PIT; Via Le Elvezia 2, 20052 Monza; tel. (039) 361-441; telex 35290

Kenya: Philips (Kenya) Ltd., P.O.B. 30554, Nairobi; tel. 29981

Malaysia: Electronic Supplies (Malaysia) Sdn Bhd. P.O. Box 332, Kuala Lumpur; tel. 564173

Mexico: Philips Comercial S.A. de C.V., Uruapan 7, Apdo 24-328, Mexico 7 D.F.; tel. 25-15-40

Nederland: Philips Nederland B.V., Boschdijk, Gebouw VB, Eindhoven; tel. 793333

Ned. Antillen: N.V. Philips Antillana, Postbus 523, Willemstad; tel. Curaçao 36222-35464

New Zealand: Philips Electronical Industries (N.Z.) Ltd., Professional and Industrial Division, 70-72 Kingsford Smith Street, P.O.B. 2097, Lyall Bay, Wellington; tel. 73-156

Nigeria: Philips (Nigeria) Ltd., Philips House, 6 Ijora Causeway, P.O.B. 1921, Lagos; tel. 45414/7

Nippon: Nihon Philips Corporation, P.O.B. 13, Trade Center, Tokyo 105; tel. (03) 435-5211

Norge: Norsk A.S. Philips, Postboks 5040, Oslo; tel. 463890

Österreich: Oesterreichische Philips Industrie GmbH, Abteilung Industrie Elektronik, Triesterstrasse 64, A-1101 Wien; tel. (0222) 645511/31

Pakistan: Philips Electrical Co. of Pakistan Ltd., El-Markaz, M.A. Jinnah Road, P.O.B. 7101, Karachi; tel. 70071

Paraguay: Philips del Paraguay S.A., Casilla de Correo 605, Asuncion; tel. 8045-5536-6666

Perú: Philips Peruana S.A., Apartado Postal 1841, Lima; tel. 326070

Philippines: Electronic Development & Application Center, 2246 Pasong Tamo Street, P.O.B. 911, Makati Commercial Center, Makati Rizal D-708; tel. 889453 to 889456

Portugal: Philips Portuguesa S.A.R.L., Rua Joaquim Antonio d'Aquiar 66, Lisboa; tel. 683121/9

Republique du Zaïre: Philips du Zaïre S.C.R.L., 137, Boulevard du 30 Juin, B.P. 1798, Kinshasa

Rwanda: Philips Rwanda S.A.R.L., B.P. 449, Kigali

Schweiz-Suisse-Svizzera: Philips A.G., Binzstrasse 38, Postfach 8027, Zürich; tel. 051-442211

Singapore: Electronic Supplies (Singapore) Private Ltd. P.O. Box 4029, Singapore 21

South Africa: South African Philips (Pty) Ltd., P.O.B. 7703, 2, Herb Street, New Doornfontein, Johannesburg; tel. 24-0531

Suomi: Oy Philips Ab, Postboks 10255, Helsinki 10; tel. 10915

Sverige: Svenska A.B. Philips, Fack, Lidingövägen 50, Stockholm 27; tel. 08/635000

Taiwan: Yung Kang Trading Co. Ltd., San Min Building, 1st Floor, 57-1 Chung Shan N Road, 2 Section, P.O.B. 1467, Taipei; tel. 577281

Tanzania: Philips (Tanzania) Ltd., p/a P.O.B. 30554, Nairobi, Kenya

Thailand: Philips Thailand Ltd., 283, Silom Road, Bangkok; tel. 36980, 36984-9

Türkiye: Türk Philips Ticaret A.S., Posta Kutusu 504, Istanbul; tel. 453250

Uruguay: Philips de Uruguay, Avda Uruguay 1287, Montevideo; tel. 956 41-2-3-4

U.S.A.: Test and Measuring Instruments Inc.; 224 Duffy Avenue, Hicksville, L.I., N.Y. 11802; tel. (516) 433-8800; telex no. 510-221-1839

Venezuela: C.A. Philips Venezolana, Apartado Postal 1167, Caracas; tel. 360511

Zambia: Philips Electrical Ltd., Professional Equipment Division, P.O.B. 553 Kitwe; tel. 2526/7/8; Lusaka P.O. Box 1878

730101

For countries not listed and for information on changes of address:

N.V. Philips
Test and Measuring Instruments Dept.
Eindhoven - Netherlands